

WARNING

CAUTION
The safe operating temperature range for this product is 41° F. - 104 °F.

PLEASE READ THE ENTIRE CONTENTS OF THIS MANUAL PRIOR TO INSTALLATION AND OPERATION. BY PROCEEDING YOU AGREE THAT YOU FULLY UNDERSTAND AND COMPREHEND THE FULL CONTENTS OF THIS MANUAL. FORWARD THIS MANUAL TO ALL OPERATORS. FAILURE TO OPERATE THIS EQUIPMENT AS DIRECTED MAY CAUSE INJURY OR DEATH.

REV A 04-11-08

INSTALLATION AND OPERATION MANUAL

**9,000 POUND CAPACITY
12,000 POUND CAPACITY
SURFACE MOUNTED
TWO-POST LIFTS**

**MODELS:
XPR-9F
XPR-9FX
XPR-12F**

VERSION A

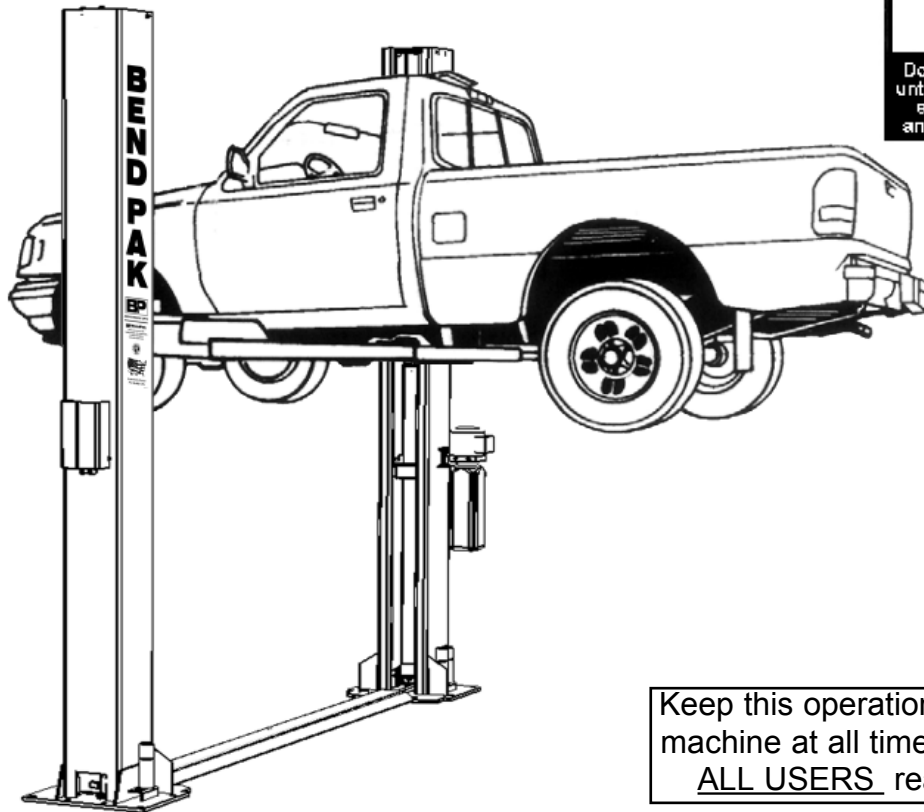

READ FIRST



Do not operate this machine until you read and understand all the dangers, warnings and cautions in this manual.

Keep this operation manual near the machine at all times. Make sure that **ALL USERS** read this manual.

SHIPPING DAMAGE CLAIMS

When this equipment is shipped, title passes to the purchaser upon receipt from the carrier. Consequently, claims for the material damaged in shipment must be made by the purchaser against the transportation company at the time shipment is received.

BE SAFE

Your new lift was designed and built with safety in mind. However, your overall safety can be increased by proper training and thoughtful operation on the part of the operator. **DO NOT** operate or repair this equipment without reading this manual and the important safety instructions shown inside.



1645 Lemonwood Dr.
Santa Paula, CA. 93060, USA
Toll Free 1-800-253-2363
Tel: 1-805-933-9970
Fax: 1-805-933-9160
www.bendpak.com

TWO-POST SURFACE MOUNTED AUTO AND LIGHT DUTY TRUCK LIFT

This instruction manual has been prepared especially for you.
Your new lift is the product of over 35 years of continuous research, testing and development;
it is the most technically advanced lift on the market today.

READ THIS ENTIRE MANUAL BEFORE INSTALLATION & OPERATION BEGINS.

RECORD HERE THE LIFT AND
POWER UNIT INFORMATION WHICH IS
LOCATED ON THE SERIAL NUMBER
DATA PLATES ON THE LIFT AND
ON THE POWER UNIT

Power Unit Model # _____
Power Unit Date Of Mfg. _____
Power Unit Serial # _____

This information is required when
calling for parts or warranty issues.

1645 Lemonwood Dr., Santa Paula, CA 93060 USA Tel: 1-805-933-9970 Fax: 1-805-933-9160 www.bendpak.com		
Model No.	Lifting Capacity	Serial No.
Date of Mfg.	Power Unit No.	Voltage / Amperage
Cable Length	A	B
Cable Diameter		

PRODUCT WARRANTY

BendPak 2-Post Lifts are covered under warranty for five years on equipment structure, to be free of defects in material and workmanship. Power units, hydraulic cylinders, and all other assembly components such as turnplates, slip plates, cables, chains, valves, switches etc. are covered under warranty for one year against defects in material or workmanship under normal use. BendPak Inc. shall repair or replace at their option for the warranty period those parts returned to the factory freight prepaid which prove upon inspection to be defective. BendPak Inc. will pay labor costs for the first 12 months only on parts returned as previously described.

The warranty does not extend to...

- ◆ defects caused by ordinary wear, abuse, misuse, shipping damage, improper installation, voltage or lack of required maintenance;
- ◆ damages resulting from purchaser's neglect or failure to operate products in accordance with instructions provided in the owner's manual(s) and/or other accompanying instructions supplied;
- ◆ normal wear items or service normally required to maintain the product in a safe operating condition;
- ◆ any component damaged in shipment;
- ◆ other items not listed but may be considered general wear parts;
- ◆ damage caused by rain, excessive humidity, corrosive environments or other contaminants.

THESE WARRANTIES DO NOT EXTEND TO ANY COSMETIC DEFECT NOT INTERFERING WITH EQUIPMENT FUNCTIONALITY OR ANY INCIDENTAL, INDIRECT, OR CONSEQUENTIAL LOSS, DAMAGE, OR EXPENSE THAT MAY RESULT FROM ANY DEFECT, FAILURE, OR MALFUNCTION OF A BENDPAK INC. PRODUCT OR THE BREACH OR DELAY IN PERFORMANCE OF THE WARRANTY.

**WARRANTY IS NOT VALID UNLESS
WARRANTY CARD IS RETURNED.**

IMPORTANT NOTICE

Do not attempt to install this lift if you have never been trained on basic automotive lift installation procedures. Never attempt to lift components without proper lifting tools such as forklift or cranes. Stay clear of any moving parts that can fall and cause injury. These instructions must be followed to insure proper installation and operation of your lift. Failure to comply with these instructions can result in serious bodily harm and void product warranty. Manufacturer will assume no liability for loss or damage of any kind, expressed or implied resulting from improper installation or use of this product.

PLEASE READ ENTIRE MANUAL PRIOR TO INSTALLATION.

DEFINITIONS OF HAZARD LEVELS

Identify the hazard levels used in this manual with the following definitions and signal words:



DANGER !

Watch for this symbol: It Means: Immediate hazards which will result in severe personal injury or death.



WARNING !

Watch for this symbol: It Means: Hazards or unsafe practices which could result in severe personal injury or death.



CAUTION !

Watch for this symbol: It Means: Hazards or unsafe practices which may result in minor personal injury, product or property damage.

OWNER'S RESPONSIBILITY

To maintain the lift and user safety, the responsibility of the owner is to read and follow these instructions:

- ◆ Follow all installation and operation instructions.
- ◆ Make sure installation conforms to all applicable Local, State, and Federal Codes, Rules, and Regulations; such as State and Federal OSHA Regulations and Electrical Codes.
- ◆ Carefully check the lift for correct initial function.
- ◆ Read and follow the safety instructions. Keep them readily available for machine operators.
- ◆ Make certain all operators are properly trained, know how to safely and correctly operate the unit, and are properly supervised.
- ◆ Allow unit operation only with all parts in place and operating safely.
- ◆ Carefully inspect the unit on a regular basis and perform all maintenance as required.
- ◆ Service and maintain the unit only with authorized or approved replacement parts.
- ◆ Keep all instructions permanently with the unit and all decals on the unit clean and visible.

BEFORE YOU BEGIN

Receiving:

The shipment should be thoroughly inspected as soon as it is received. The signed bill of lading is acknowledgement by the carrier of receipt in good condition of shipment covered by your invoice. If any of the goods called for on this bill of lading are shorted or damaged, do not accept them until the carrier makes a notation on the freight bill of the shorted or damaged goods. Do this for your own protection.

NOTIFY THE CARRIER AT ONCE if any hidden loss or damage is discovered after receipt and request the carrier to make an inspection. If the carrier will not do so, prepare a signed statement to the effect that you have notified the carrier (on a specific date) and that the carrier has failed to comply with your request.

IT IS DIFFICULT TO COLLECT FOR LOSS OR DAMAGE AFTER YOU HAVE GIVEN THE CARRIER A CLEAR RECEIPT. File your claim with the carrier promptly. Support your claim with copies of the bill of lading, freight bill, invoice, and photographs, if available. Our willingness to assist in helping you process your claim does not make BendPak responsible for collection of claims or replacement of lost or damaged materials.

TABLE OF CONTENTS

<u>Contents</u>	<u>Page No.</u>
Warranty / Serial Number Information	2
Definitions of Hazard Levels	3
Owner's Responsibility	3
Before You Begin.	3
Installers Agreement / Operator Protective Equipment.	5
Introduction	6
Safety / Warning Instructions	6
Tools Required.	7
Step 1 / Selecting Site	7
Step 2 / Floor Requirements	7
Concrete Specifications.	7
Assembly View / Description of Parts	8
Step 3 / Preparing the Columns	9-10
Floorplan / Specifications	11
Step 4 / Site Layout	11
Step 5 / Installing Powerside Columns	12
Step 6 / Installing Offside Columns.	12
Step 7 / Mounting Power Unit	13
Step 8 Installing Safeties and Safety Cables	14-15
Step 9 / Installing Hydraulic Hoses	16
Step 10 / Installing Equalizer Cables.	17-18
Step 11 / Installing Powerside and Offside Safety Covers	19
Step 12 / Installing Lift Arms	20-21
Step 13 / Power Unit Hookup.	23-24
Step 14 / Lift Start Up	24
Step 15 / Lubrication	25
Optional Equipment Installation.	26-27
Step 16 / Operation/ Maintenance	28-34
Troubleshooting Guide	35-38
Maintenance Records.	39
Part Number Lists	40-46
Installation Form	47

**INSTALLER / OPERATOR
PLEASE READ AND FULLY
UNDERSTAND.
BY PROCEEDING YOU AGREE TO
THE FOLLOWING.**

- ◆ I have visually inspected the site where the lift is to be installed and verified the concrete to be in good condition and free of cracks or other defects. I understand that installing a lift on cracked or defective concrete could cause lift failure resulting in personal injury or death.
- ◆ I understand that a level floor is required for proper installation and level lifting.
- ◆ I understand that I am responsible if my floor is of questionable slope and that I will be responsible for all charges related to pouring a new level concrete slab if required and any charges.
- ◆ I understand that the lifts are supplied with concrete fasteners meeting the criteria of the American National Standard "Automotive Lifts -Safety Requirements for Construction, Testing, and Validation" ANSI/ALI ALCTV-1998, and that I will be responsible for all charges related to any special regional structural and/or seismic anchoring requirements specified by any other agencies and/or codes such as the Uniform Building Code (UBC) and/or International Building Code (IBC).
- ◆ I will assume full responsibility for the concrete floor and condition thereof, now or later, where the above equipment model(s) are to be installed. Failure to follow danger, warning, and caution instructions may lead to serious personal injury or death to operator or bystander or damage to property.
- ◆ I understand that Bendpak lifts are designed to be installed in indoor locations only. Failure to follow installation instructions may lead to serious personal injury or death to operator or bystander or damage to property or lift.



Failure to follow danger, warning, and caution instructions may lead to serious personal injury or death to operator or bystander or damage to property.



Please read entire manual prior to installation. Do not operate this machine until you read and understand all the dangers, warnings and cautions in this manual. For additional copies or further information, contact:

BendPak Inc. / Ranger Products

1645 Lemonwood Dr.

Santa Paula, CA. 93060

1-805-933-9970

www.bendpak.com

**INSTALLER / OPERATOR
PROTECTIVE EQUIPMENT**

Personal protective equipment helps makes installation and operation safer, however, it does not take the place of safe operating practices. Always wear durable work clothing during any installation and/or service activity. Shop aprons or shop coats may also be worn, however loose fitting clothing should be avoided. Tight fitting leather gloves are recommended to protect technician hands when handling parts. Sturdy leather work shoes with steel toes and oil resistant soles should be used by all service personnel to help prevent injury during typical installation and operation activities.

Eye protection is essential during installation and operation activities. Safety glasses with side shields, goggles, or face shields are acceptable. Back belts provide support during lifting activities and are also helpful in providing worker protection. Consideration should also be given to the use of hearing protection if service activity is performed in an enclosed area, or if noise levels are high.



THIS SYMBOL POINTS OUT IMPORTANT SAFETY INSTRUCTIONS WHICH IF NOT FOLLOWED COULD ENDANGER THE PERSONAL SAFETY AND/OR PROPERTY OR YOURSELF AND OTHERS AND CAN CAUSE PERSONAL INJURY OR DEATH. READ AND FOLLOW ALL INSTRUCTIONS IN THIS MANUAL BEFORE ATTEMPTING TO OPERATE THIS MACHINE.

INTRODUCTION

1. Carefully remove the crating and packing materials. **CAUTION!** Be careful when cutting steel banding material as items may become loose and fall causing personal harm or injury.

2. Check the voltage, phase and proper amperage requirements for the motor shown on the motor plate. Wiring should be performed by a certified electrician only.

IMPORTANT SAFETY INSTRUCTIONS

Read these safety instructions entirely!

IMPORTANT NOTICE

Do not attempt to install this lift if you have never been trained on basic automotive lift installation procedures. Never attempt to lift components without proper lifting tools such as forklift or cranes.

Stay clear of any moving parts that can fall and cause injury.

1. **READ AND UNDERSTAND** all safety warning procedures before operating lift.

2. **KEEP HANDS AND FEET CLEAR.** Remove hands and feet from any moving parts. Keep feet clear of lift when lowering. Avoid pinch points.

3. **KEEP WORK AREA CLEAN.** Cluttered work areas invite injuries.

4. Consider work area environment. Do not expose equipment to rain. **DO NOT** use in damp or wet locations. Keep area well lighted.

5. **ONLY TRAINED OPERATORS** should operate this lift. All non-trained personnel should be kept away from work area. Never let non-trained personnel come in contact with, or operate lift.

6. **USE LIFT CORRECTLY.** Use lift in the proper manner. Never use lifting adapters other than what is approved by the manufacturer.

7. **DO NOT** override self-closing lift controls.

8. **REMAIN CLEAR** of lift when raising or lowering vehicle.

9. **CLEAR AREA** if vehicle is in danger of falling.

10. **ALWAYS INSURE** that the safeties are engaged before any attempt is made to work on or near vehicle.

11. **DRESS PROPERLY.** Non-skid steel-toe footwear is recommended when operating lift.

12. **GUARD AGAINST ELECTRIC SHOCK.** This lift must be grounded while in use to protect the operator from electric shock. Never connect the green power cord wire to a live terminal. This is for ground only.



13. **DANGER!** The power unit used on this lift contains high voltage. Disconnect power at the receptacle before performing any electrical repairs. Secure plug so that it cannot be accidentally plugged in during service.



14. **WARNING! RISK OF EXPLOSION.** This equipment has internal arcing or sparking parts which should not be exposed to flammable vapors. This machine should not be located in a recessed area or below floor level.



15. **MAINTAIN WITH CARE.** Keep lift clean for better and safer performance. Follow manual for proper lubrication and maintenance instructions. Keep control handles and/or buttons dry, clean and free from grease and oil.

16. **STAY ALERT.** Watch what you are doing. Use common sense. Be aware.

17. **CHECK FOR DAMAGED PARTS.** Check for alignment of moving parts, breakage of parts or any condition that may affect its operation. Do not use lift if any component is broken or damaged.

18. **NEVER** remove safety related components from the lift. Do not use lift if safety related components are damaged or missing.

TOOLS REQUIRED

- ◆ Rotary Hammer Drill or Similar
- ◆ 3/4" Masonry Bit
- ◆ Hammer
- ◆ 4 Foot Level
- ◆ Open-End Wrench Set: 7/16" - 1-1/8"
- ◆ Socket And Ratchet Set: 7/16" - 1-1/8"
- ◆ Hex-Key / Allen Wrench Set
- ◆ Large Crescent Wrench
- ◆ Large Pipe Wrench
- ◆ Crow Bar
- ◆ Chalk Line
- ◆ Medium Flat Screwdriver
- ◆ Tape Measure: 25 Foot Minimum
- ◆ Needle Nose Pliers

IMPORTANT NOTICE

These instructions must be followed to insure proper installation and operation of your lift. Failure to comply with these instructions can result in serious bodily harm and void product warranty. Manufacturer will assume no liability for loss or damage of any kind, expressed or implied resulting from improper installation or use of this product.

PLEASE READ ENTIRE MANUAL PRIOR TO INSTALLATION.

STEP 1

(Selecting Site)

Before installing your new lift, check the following.

1. **LIFT LOCATION:** Always use architects plans when available. Check layout dimension against floorplan requirements making sure that adequate space is available.
2. **OVERHEAD OBSTRUCTIONS:** The area where the lift will be located should be free of overhead obstructions such as heaters, building supports, electrical lines etc.
3. **DEFECTIVE FLOOR:** Visually inspect the site where the lift is to be installed and check for cracked or defective concrete.



4. **OPERATING TEMPERATURE.** Operate lift only between temperatures of 41° -104° F.
5. Lift is designed for **INDOOR INSTALLATION ONLY.**

STEP 2

(Floor Requirements)



This lift must be installed on a solid level concrete floor with no more than 3-degrees of slope. Failure to do so could cause personal injury or death.

A level floor is suggested for proper use and installation and level lifting. If a floor is of questionable slope, consider a survey of the site and/or the possibility of pouring a new level concrete slab.



- ◆ **DO NOT** install or use this lift on any asphalt surface or any surface other than concrete.
- ◆ **DO NOT** install or use this lift on expansion seams or on cracked or defective concrete.
- ◆ **DO NOT** install or use this lift on a second / elevated floor without first consulting building architect.
- ◆ **DO NOT** install or use this lift outdoors.

CONCRETE SPECIFICATIONS

LIFT MODEL	CONCRETE REQUIREMENTS
9,000 Lb Models	4" Min. Thickness / 3,000 PSI
12,000 Lb Models	6" Min. Thickness / 3,000 PSI



All models **MUST** be installed on 3000 PSI concrete only conforming to the minimum requirements shown above. New concrete must be adequately cured by at least 28 days minimum.

⚠ DANGER

When removing the lift from shipping angles pay close attention as the posts can slide and can cause injury. Prior to removing the bolts make sure the posts are held securely by a fork lift or some other heavy lifting devise.

PARTS INVENTORY

Be sure to take a complete inventory of parts prior to beginning installation.

Description	Qty
Floorplate	1
Front Arm Assembly	2
Rear Arm Assembly	2
Offside Column with Lift Head Assembly	1
Powerside Column with Lift Head Assembly	1
Hydraulic Cylinder	2
Parts Box (Packing List Enclosed)	1
Parts Bag (Packed in Part Box)	1
Hydraulic Power Unit	1

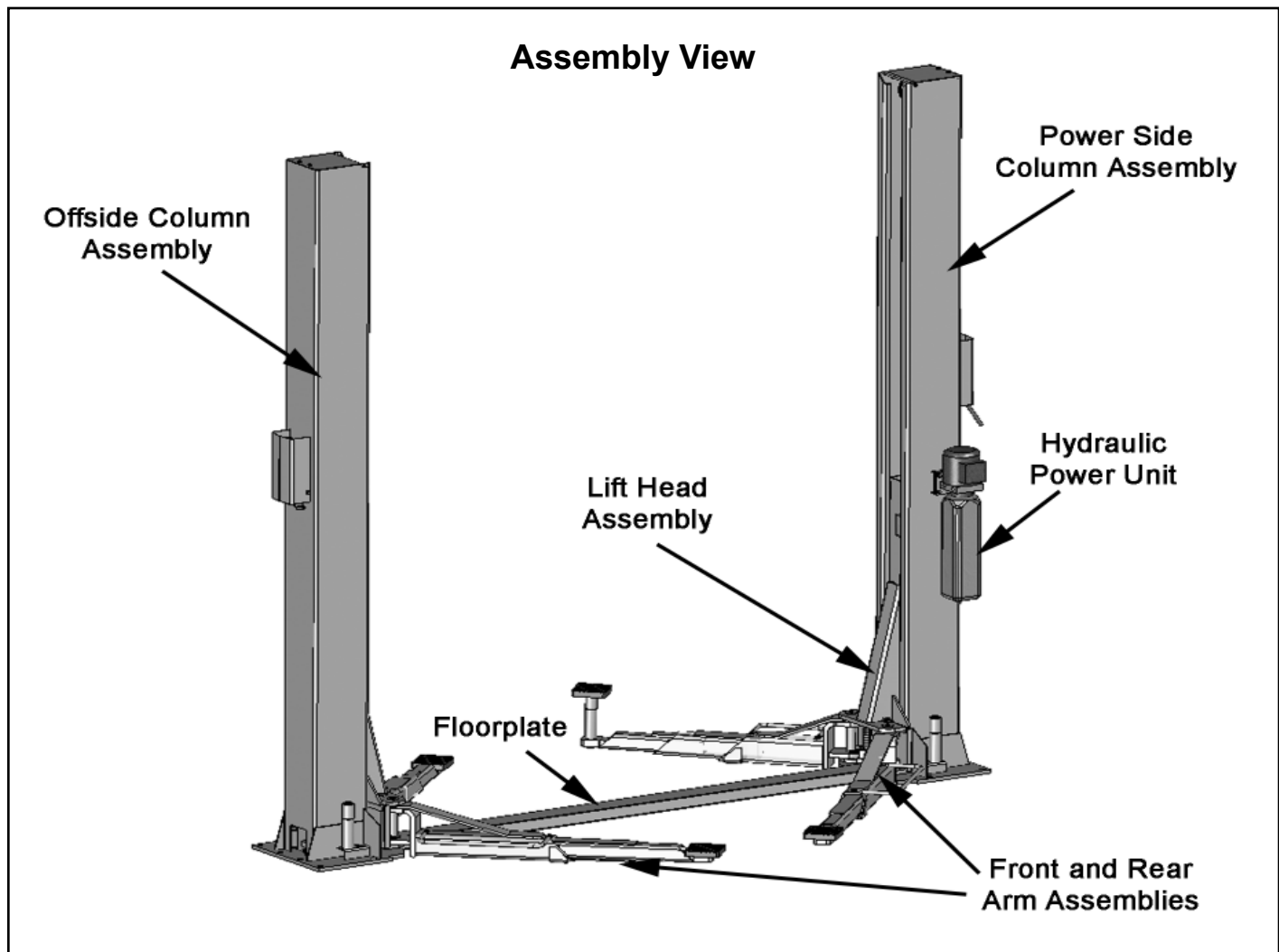

STEP 3

(Column Preparation)

COMPLETE THE FOLLOWING PRIOR TO STANDING UP COLUMNS.

1. Lay the Columns on the floor, slide the Carriage up towards to the top of the Columns just enough to gain access to the Port on the base of the Cylinder. Remove the Hair Clip pins and remove the Bottom Sheave Cover. (See Figs. 3.1 & 3.2)

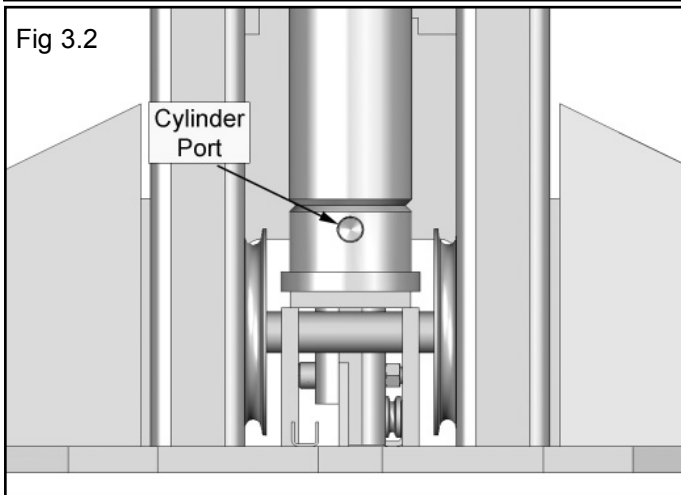
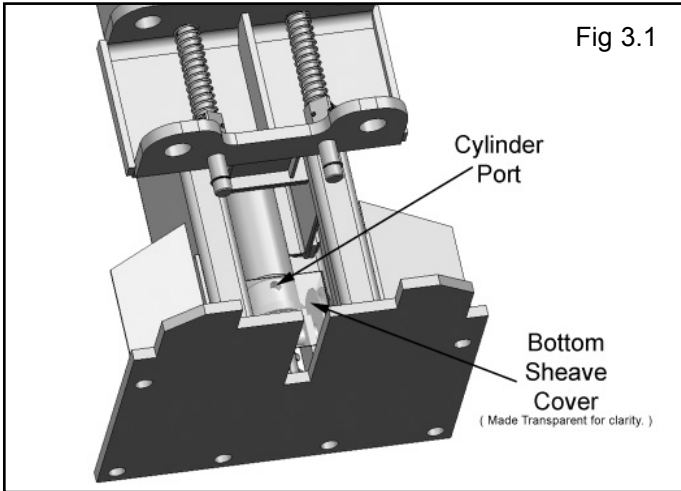

2. Install the 90° 3/8" Fitting into the Cylinder port using Teflon tape on the pipe threads. (See Fig. 3.3)

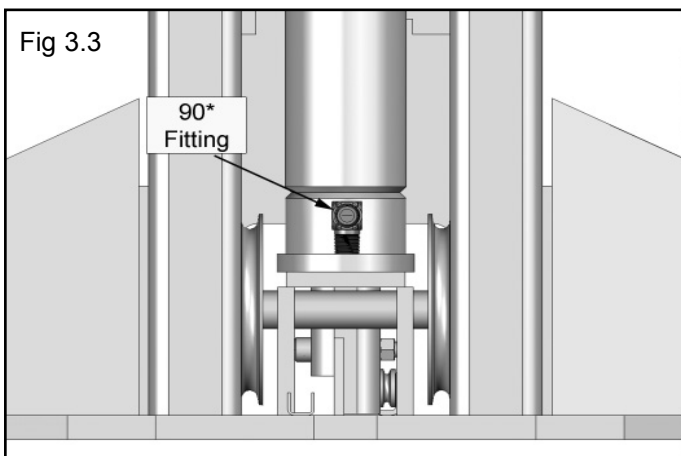

3. Assemble the Tube Fitting and 3/8" to 1/4" Hose Fitting together. Use Teflon tape on all pipe threads making sure that all pieces are fitted together as tight as possible. **DO NOT** use Teflon tape on the JIC hose fittings. (See Fig. 3.4)

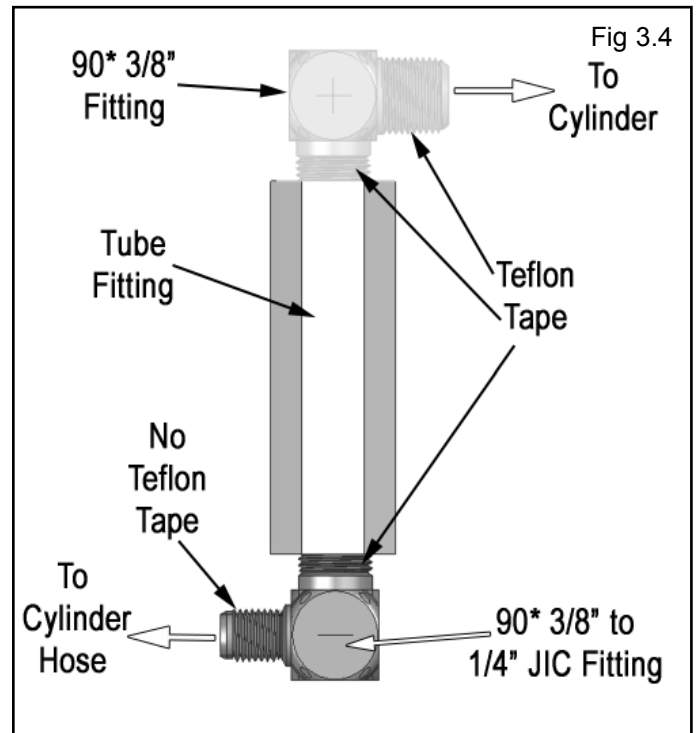

4. Connect Tube Fitting Assembly to the 90° 3/8 Fitting that was installed into the Cylinder port, using Teflon tape on the pipe threads. (See Fig. 3.5)

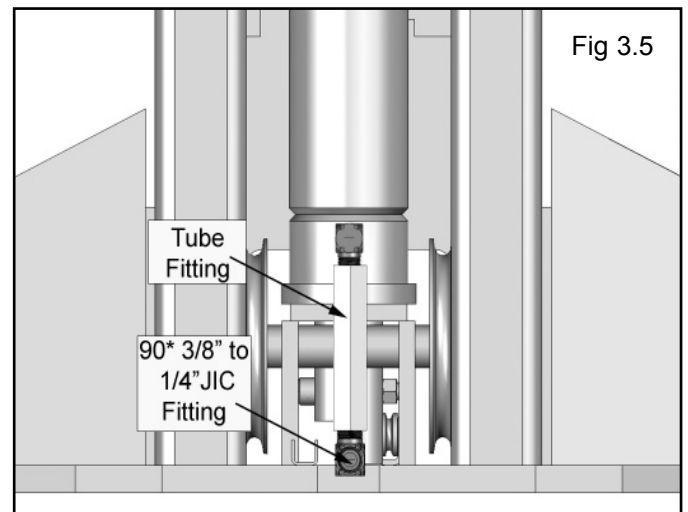

**Failure to Tighten the tube fittings properly
can cause damage to the lift**

5. Ensure the Cylinder seats back into the Mounting Bracket and the Cylinder Leveling Plug sits in the hole in the bottom of the Cylinder. (See Fig 3.6)

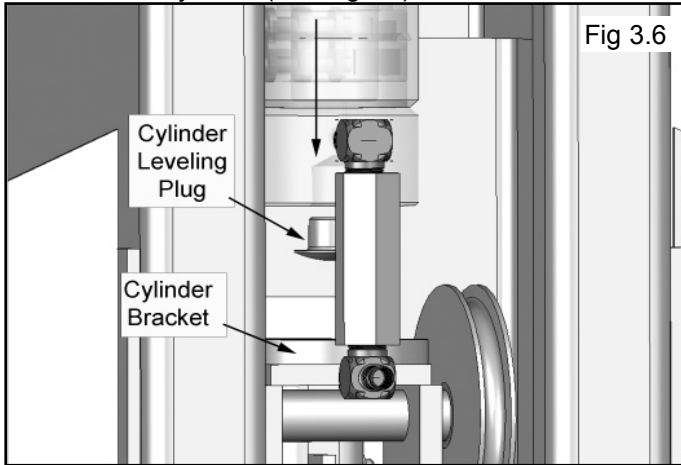

NOTE:
Refer to Step 12 for Cable Routing details.
Route Button End of Cables Prior to standing up the Columns.

8. Repeat Step 3, Items 1-7 for the Offside Column.

9. Stand the Columns up and place them in position to be mounted to the floor.

10. Proceed to Step 4.

6. Route the Button End of the Equalizer Cable through the Cable Retainer located inside the Carriage on the front wall, up to the Top Plate Pulley, around the Pulley and coil the remaining Cable up and leave it in the Column above the Carriage. (See Fig 3.7)

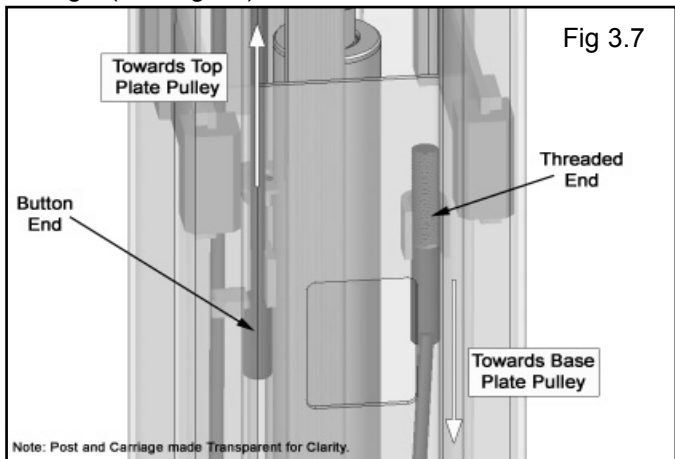

Note: Post and Carriage made Transparent for Clarity.

7. Bolt the Top Plate Assembly to the Column using the M10 Bolts, Washers and Nuts provided in the parts box. (See Fig 3.8)

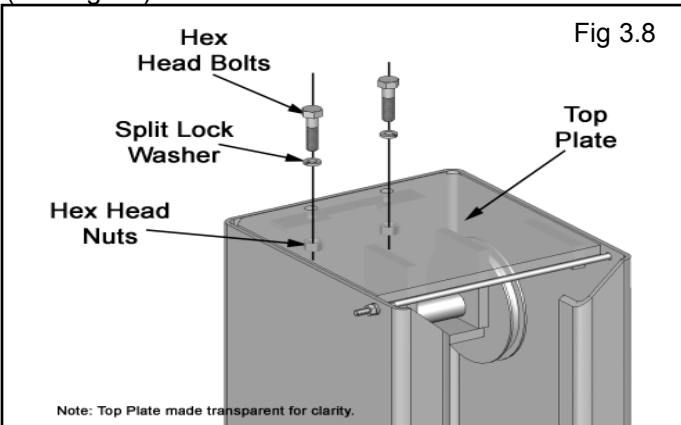

Note: Top Plate made transparent for clarity.

FLOORPLAN / LAYOUT

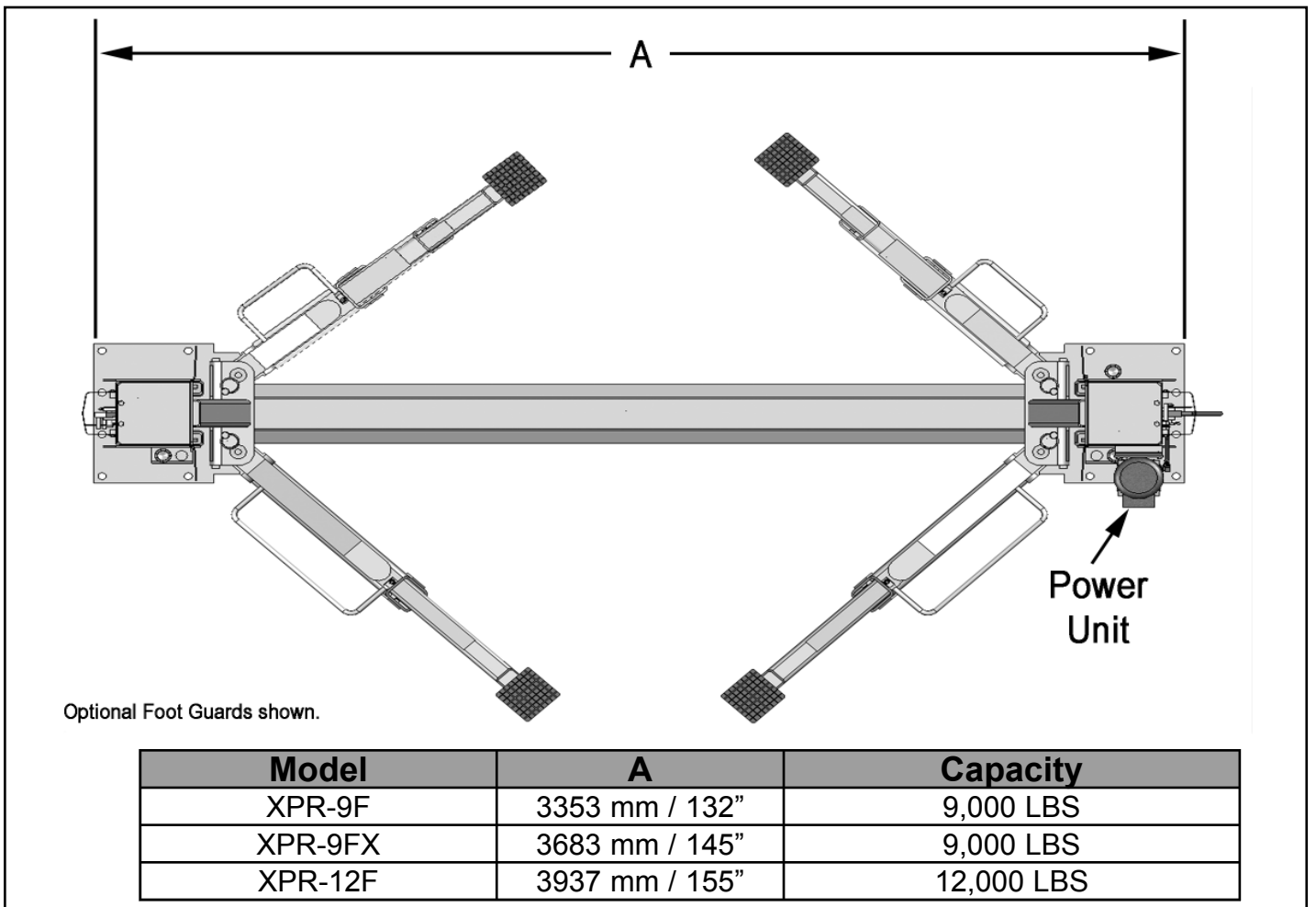

STEP 4

(Site Layout)

1. Determine which side will be the approach side.
2. Now determine where the Power Unit will be located. The POWERSIDE Column has the Power Unit Mounting Bracket attached to the side.
3. Once a location is determined, use a carpenters chalk line to layout a grid for the Column locations. Keep all dimensions and squareness within 1/8" or malfunctioning of the lift can occur.
4. After the Column locations are properly marked, use a chalk or crayon to make an outline of the Column on the floor at each location using the Column base plates as a template. (See Fig 4.1)
5. **Double check** all dimensions and make sure that the layout is perfectly square.

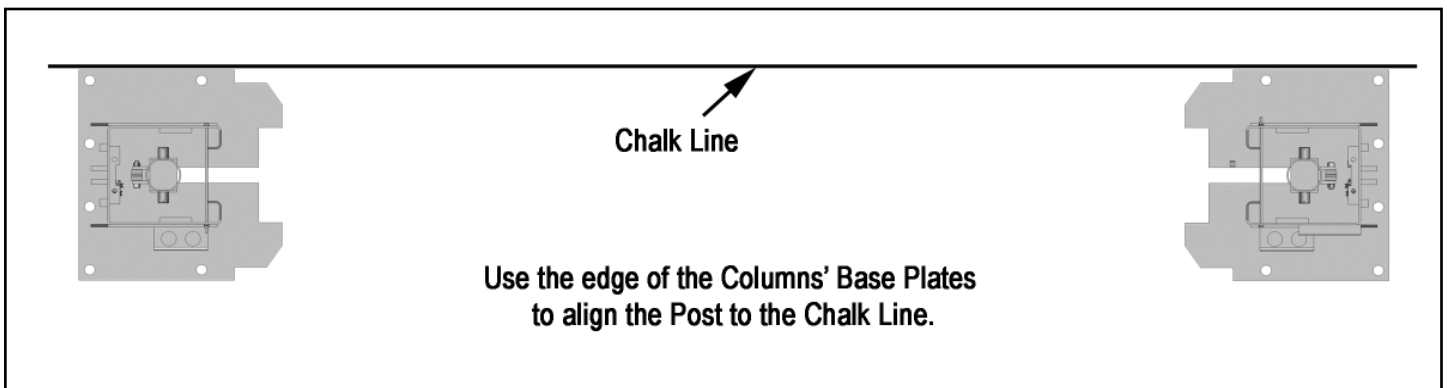

STEP 5

(Installing Powerside Column)

1. Before proceeding, double the check measurements and make certain that the bases of each Column are aligned with the chalk line.

2. Using the base plate on the POWERSIDE Column as a guide, drill each anchor hole in the concrete (approximately 4-1/2" deep for 9K models and 6" deep for 12K models) using a rotary hammer drill and 3/4" concrete drill-bit. To assure full holding power, do not ream the hole or allow the drill to wobble. (See Fig. 5.1)

Fig 5.1

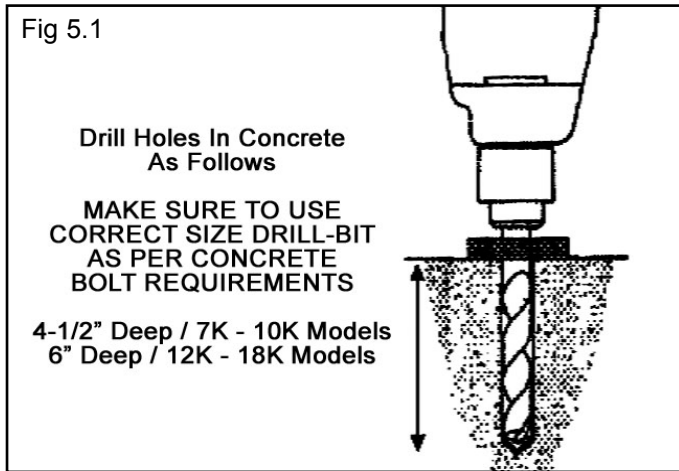

3. After drilling, remove dust thoroughly from each hole making certain that the Column remains aligned with the chalk line.

4. Assemble the washers and nuts on the anchors then tap into each hole with a hammer until the washer rests against the base plate. Be sure that if shimming is required that enough threads are left exposed. (See Fig. 5.2)

Fig 5.2

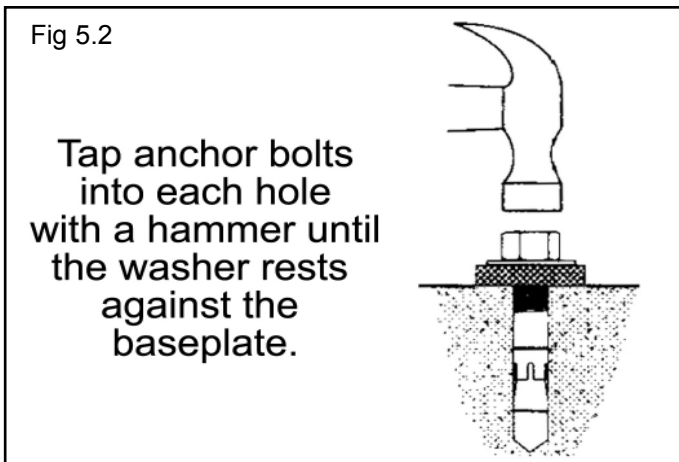

5. If shimming is required, insert the shims as necessary under the base plate so that when the anchor bolts are tightened, the columns will be plumb. (See Fig. 5.3)

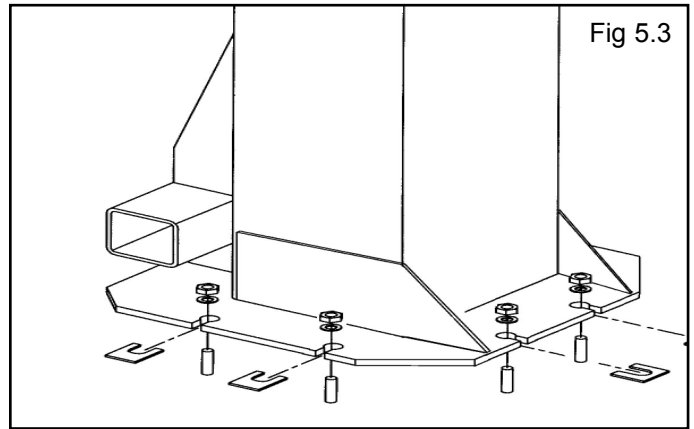

6. With the shims and anchor bolts in place, tighten by securing the nut to the base then turning 2 - 3 full turns clockwise. **DO NOT** use an impact wrench for this procedure. (See Fig 5.4)

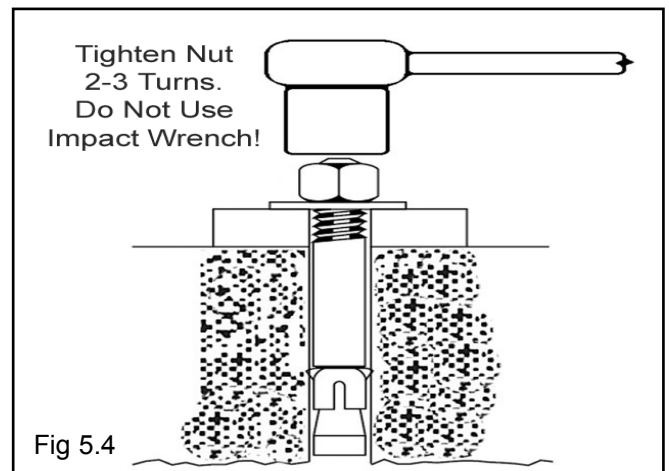

STEP 6

(Installing The OFFSIDE column.)

1. Position the OFFSIDE column at the designated chalk locations and secure to the floor following the same procedures as outlined in STEP FIVE; Items 1-6.

STEP 7

(Mounting the Hydraulic Power Unit)

1. Attach the Power Unit to the POWERSIDE COLUMN. install the Vibration Dampner between the Power Unit and the Power Unit Mounting Plate on the Powerside Column., using four M8 Hex Bolts and Nuts supplied. (See Fig 7.1)

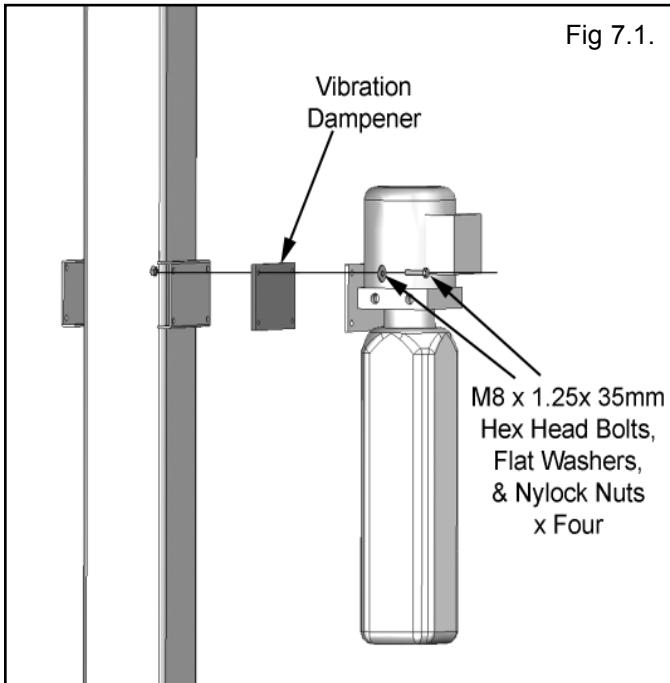

2. Fill the reservoir with 10 WT. HYDRAULIC OIL OR DEXRON TYPE III ATF, approximately four gallons. Make sure the funnel used to fill the power unit is clean.

Do not connect Power Unit Hydraulic Hose Assy at this time.

3. The standard power unit for your lift is 220 volt, 60HZ, single phase. All wiring must be performed by a certified electrician only. SEE WIRING INSTRUCTIONS AFFIXED TO MOTOR FOR PROPER WIRING INSTRUCTIONS.

! DANGER

**DANGER !
ALL WIRING MUST BE PERFORMED
BY A LICENSED ELECTRICIAN.**

! DANGER



DANGER!

**DO NOT PERFORM ANY MAINTENANCE OR
INSTALLATION OF ANY COMPONENTS WITH OUT
FIRST ENSURING THAT ELECTRICAL POWER HAS
BEEN DISCONNECTED AT THE SOURCE OR PANEL
AND CANNOT BE RE-ENERGIZED UNTIL ALL
MAINTENANCE AND/OR INSTALLATION
PROCEDURES ARE COMPLETED.**

! WARNING

**DO NOT run power unit with no oil. Damage to pump can occur.
The power unit must be kept dry. Damage to power unit caused by water or other liquids such as
detergents, acid etc., is not covered under warranty.**

Operate lift only between temperatures of 41 °- 104° F.

Improper electrical hook-up can damage motor and will not be covered under warranty.

Motor can not run on 50HZ without a physical change in motor.

Use a separate breaker for each power unit.

Protect each circuit with time delay fuse or circuit breaker.

For 208-230 volt, single phase, use a 25 amp fuse.

For 208-230 volt, three phase, use a 20 amp fuse.

For 380-440 volt, three phase, use a 15 amp fuse.

STEP 8

(Installing the Safeties and Safety cable)

1. Install Safety Weldments into each respective Column. (See Figs 8.1 & 8. 2.).

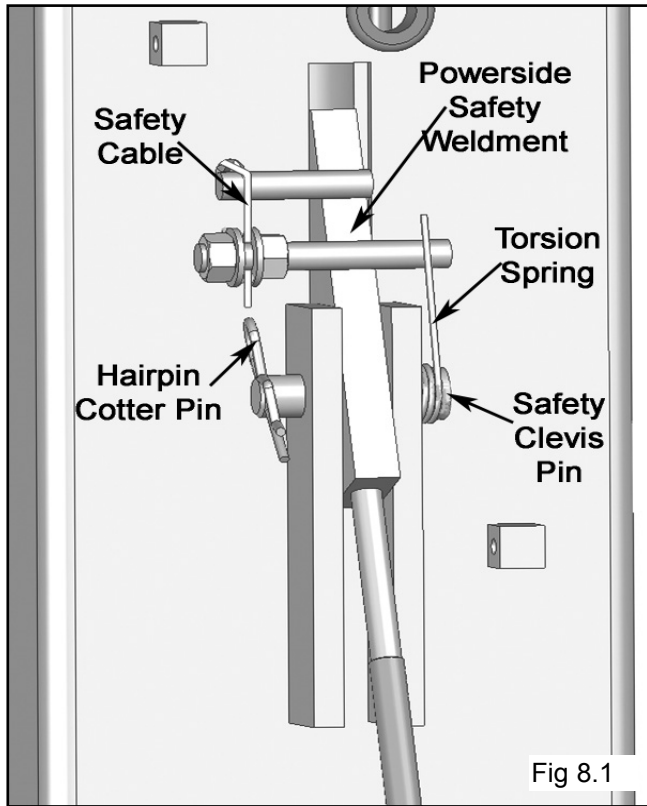

2. From the Offside Column insert the non looped end of the Safety Cable through the hole located to the right of the Offside Safety Weldment. (See Fig 8.3)

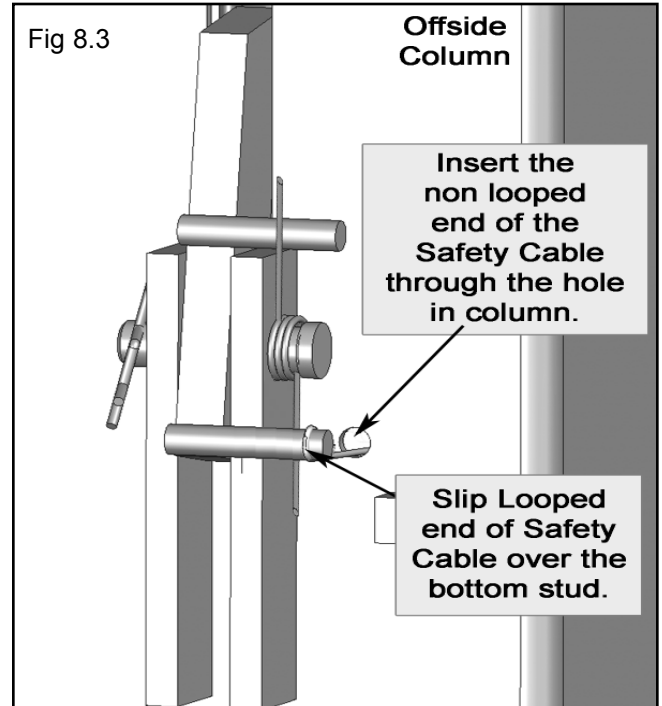

3. Route the Cable over the Safety Cable Pulley and take it down to the Base Plate Pulley. (See Fig 8.4)

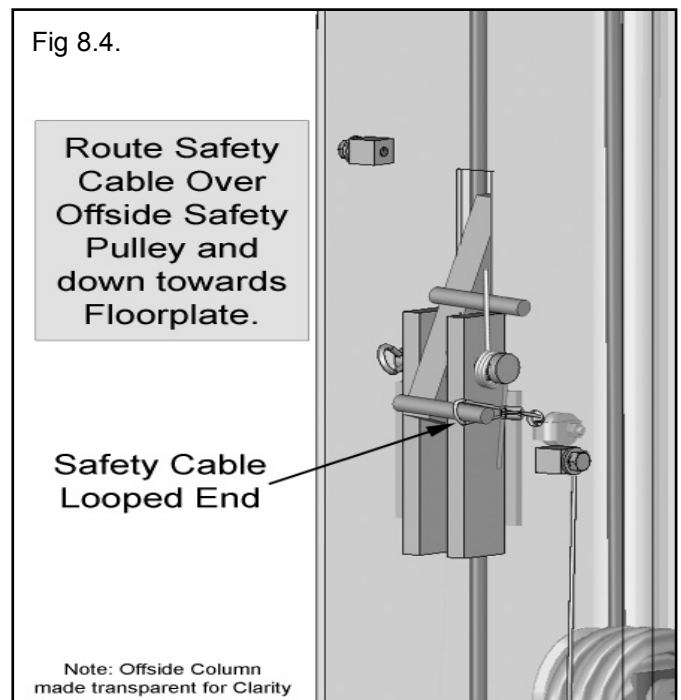
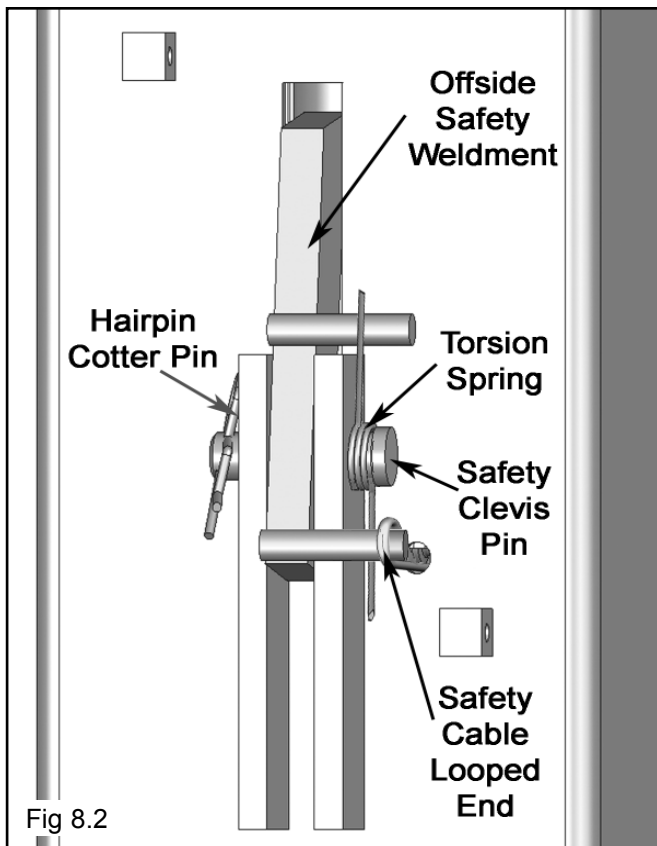

4. Route the Safety Cable through the Base Plate Safety Cable Pulley(s) and across the floor towards the Powerside Column. (See Figs 8.5 & 8.6)

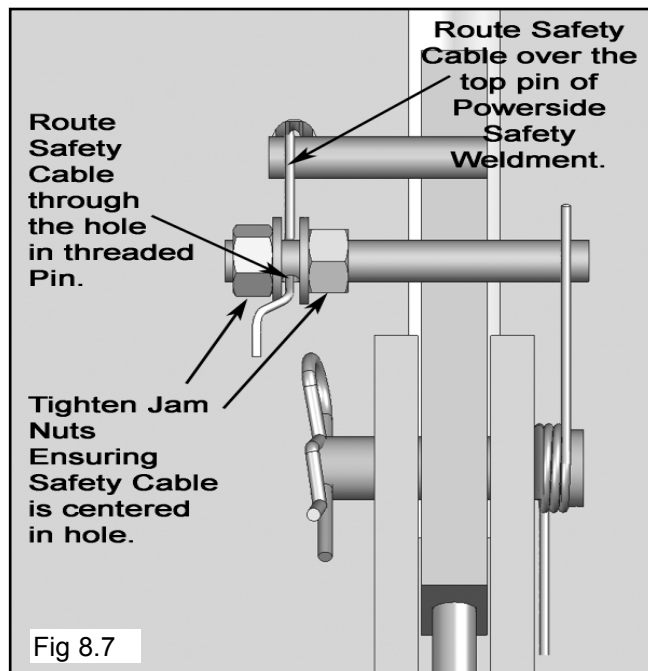
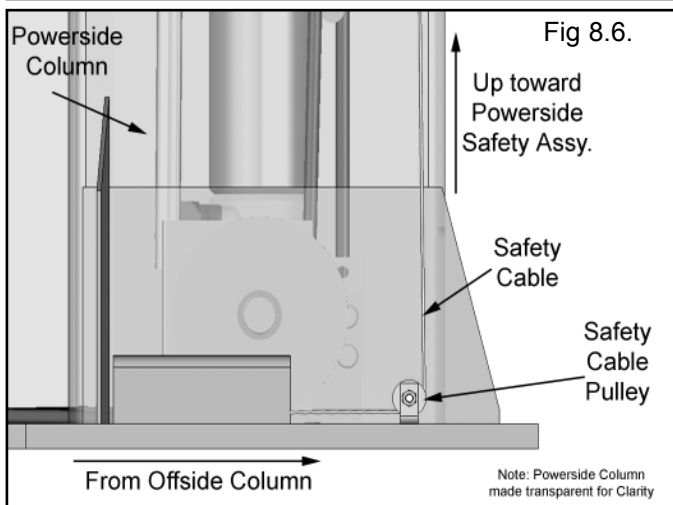
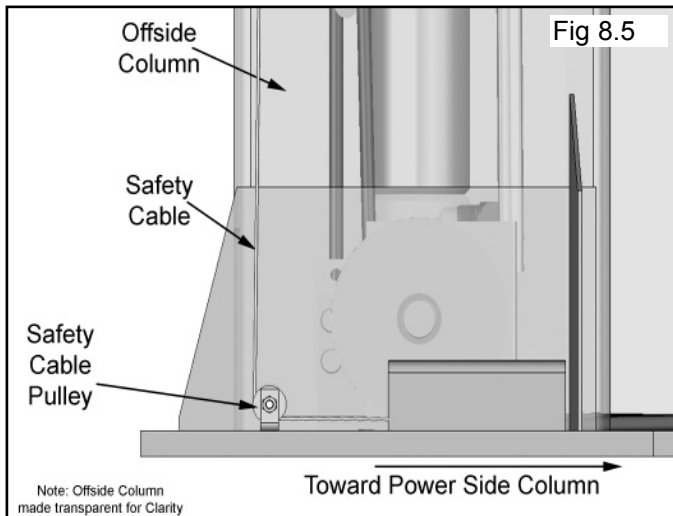

8. Operate the Power Side Safety Handle, check for Proper Operation of both Safety Assemblies and adjust Cable tension as required.



DANGER !
ENSURE THAT BOTH THE
POWERSIDE & OFFSIDE SAFETIES ENGAGE
PROPERLY PRIOR TO LIFT OPERATION.

5. Route the Safety Cable up the Power Side Column going towards the Power Side Safety Cable Pulley.

6. Route the Safety Cable over the Power Side Safety Cable Pulley, through the hole in the Column and over the top Pin on the Safety Handle. Insert the Cable end through the hole on the threaded Pin. (See Fig 8.7)

7. Pull the slack out the Safety Cable and hold tension as the Cable is being tightened. Tighten Jam Nuts on either side of the Cable to secure it into place. (See Fig 8.7)



Make sure to tighten both nuts equally so as to keep the safety cable centered

STEP 9

(Installing Hydraulic Lines)



DANGER !

Make sure that the Safety Locks on each Column are fully engaged before attempting to route Equalizer Cables and/or Hoses. Carriages must be equal height from the floor before proceeding.

1. Raise and lock each Carriage approximately 28" above the ground. (See Fig. 9.1)

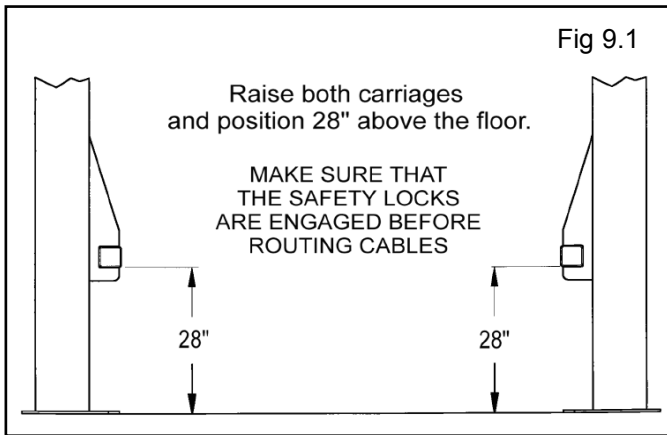

WARNING!

When routing the Hydraulic Hose through the Columns, make sure to route through the retaining rings welded inside each Column. Make sure that the Hose is clear of any moving parts. It may be necessary to tie Hose clear by using nylon tie straps or wire.

2. With the Carriages locked at 28" off the floor, route the Hydraulic Hoses.
3. Connect the Tee Fitting to the 90° Fitting. Connect the Power Unit Hose to the 90° Fitting.
4. Connect the Powerside Cylinder Hose to the Tee Fitting. Ensure that the Power Unit Hose and Powerside Hose Assy. are pointing in the same direction.
5. Connect the Offside Cylinder Hose to the other side of the Tee Fitting. (See Fig 9.2)

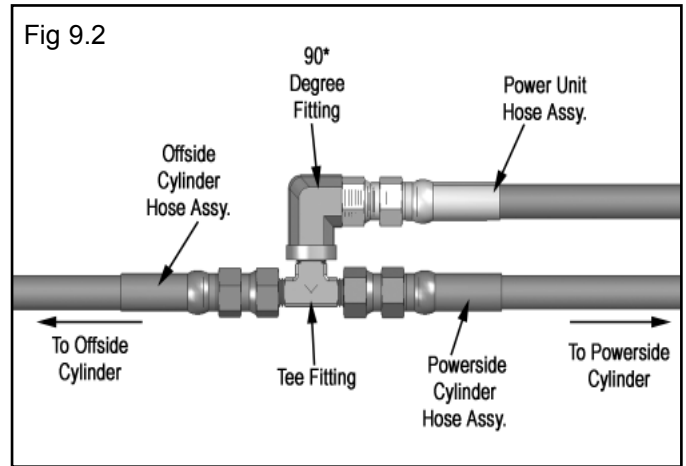

6. Bottom Sheave Cover should be removed for access. Connect the Offside Cylinder Hose to the Tube Fitting Assy. of the Offside Cylinder. (See Fig. 9.3)

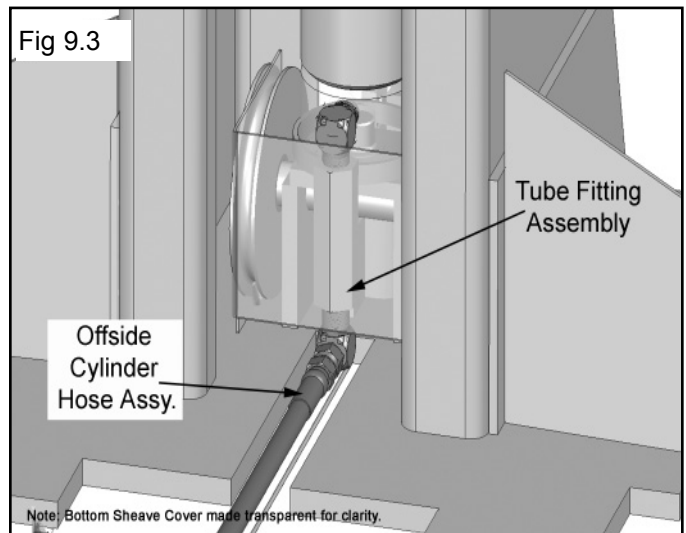

7. Connect the Powerside Hose Assy. to the Tube Fitting of the Powerside Cylinder. Run the Power Unit Hose Assy. through the Retaining Clips on the Base Plate. (See Fig. 9.4)

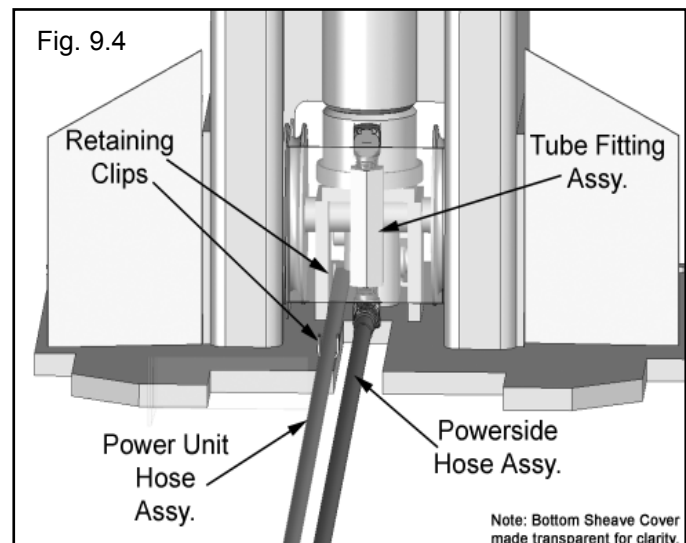

8. Remove plug from Power Unit and install the 90° Fitting w/ O-ring into the Power Port on the Power Unit. Use Teflon Tape on the Pipe Fitting side **ONLY**.

9. Run the Power Unit Hose up the outside of the Powerside Column and connect to the Power Unit Fitting. (See Fig. 9.5)

STEP 10

(Routing the EQUALIZER CABLES)



WARNING!

WHEN THE CABLE ADJUSTING NUTS BOTTOM OUT ON THE THREADED END OF THE CABLE CONNECTOR AND THERE IS STILL SLACK IN THE CABLES, THE CABLES HAVE STRETCHED BEYOND THE SAFE USEFUL LENGTH AND NEED TO BE REPLACED WITH FACTORY APPROVED CABLE ASSEMBLIES. DO NOT PLACE WASHERS, SPACERS OR OTHER DEVICES TO "SHORTEN" THE EFFECTIVE CABLE LENGTH AS DAMAGE TO THE LIFT OR INJURY TO PERSONS MAY OCCUR.

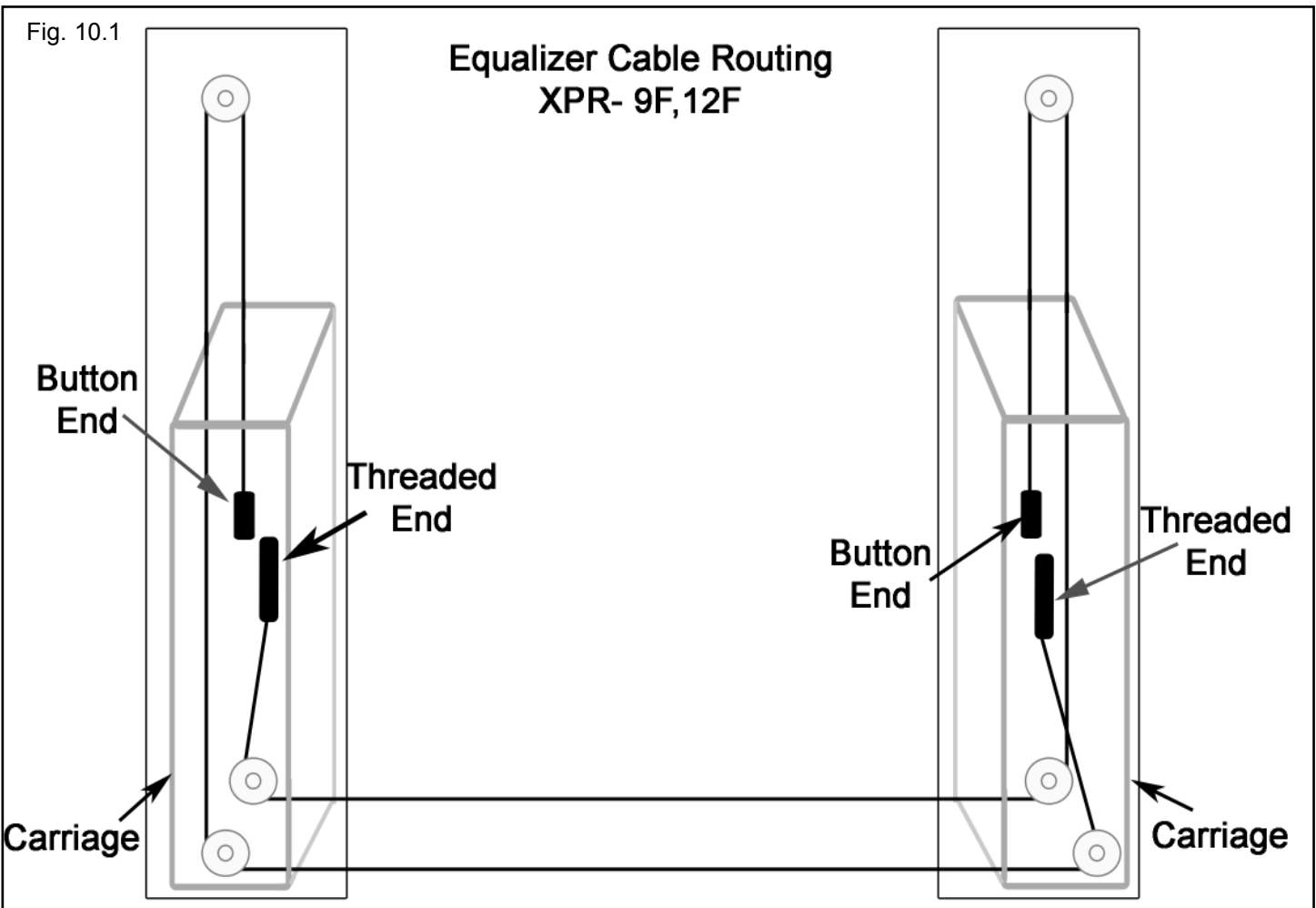
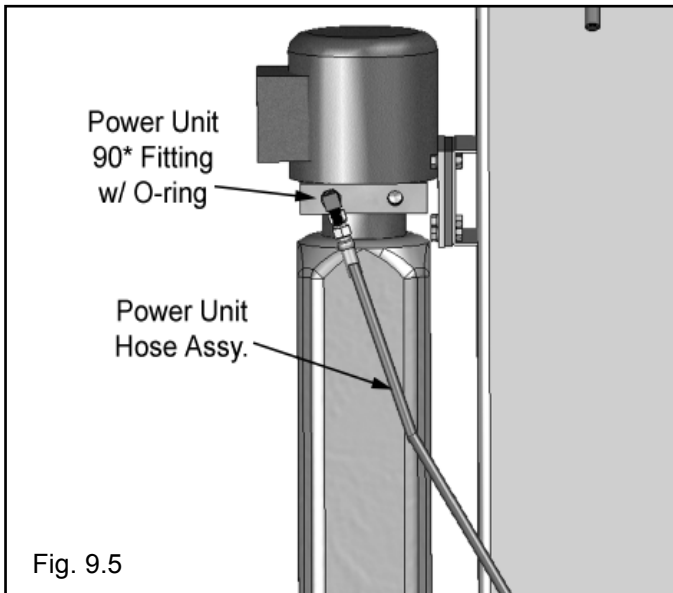

! DANGER

DANGER !
 Make sure that the safety locks on each column are fully engaged before attempting to route equalizer cables and/or hoses. Carriages must be equal height from the floor before proceeding.

NOTE:
 The Equalizer Pulleys should be removed to assist in the routing of the Equalizer Cables.

1. With the Carriages locked at 28" off the floor, route the Equalizer cables as shown below and in Fig. 10.1.

2. Run the Button end of the Cable down through the top of the Carriage and into the clip in the Carriage. (See Fig. 10.2)

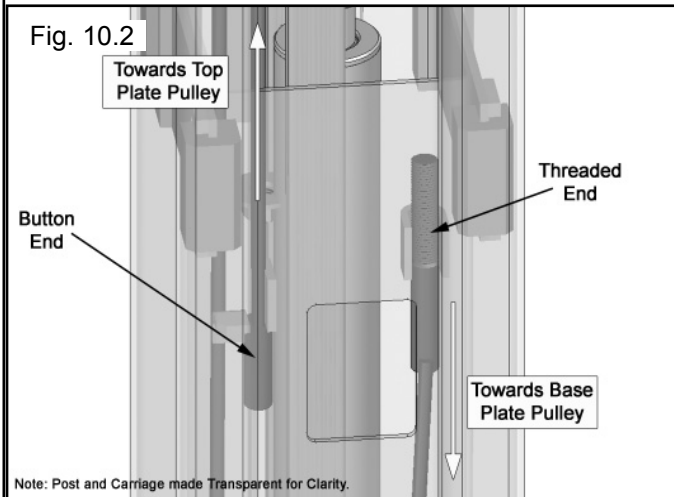

3. Route the Cable around the Top Plate Pulley and back down towards the Carriage. (See Fig. 10.3)

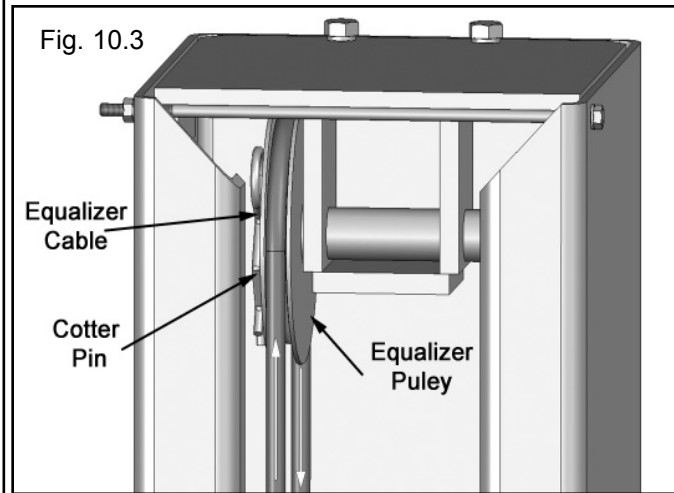

4. Run the Threaded end through the Carriage around the Base Plate Pulley across the floor to the opposite Base Plate Pulley. (See Fig. 10.4)

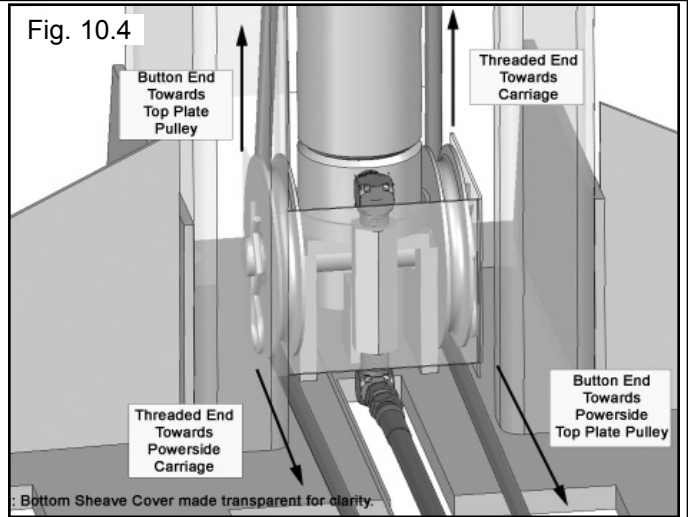

5. Run the threaded Cable end up to the U-shaped Slot in the Carriage.

6. Feed the threaded end up through the U-shaped slot in the Carriage. Place Washer and Nylock Nut on the Threaded end and tighten till the Cable is just taut. (See Fig. 10.5)

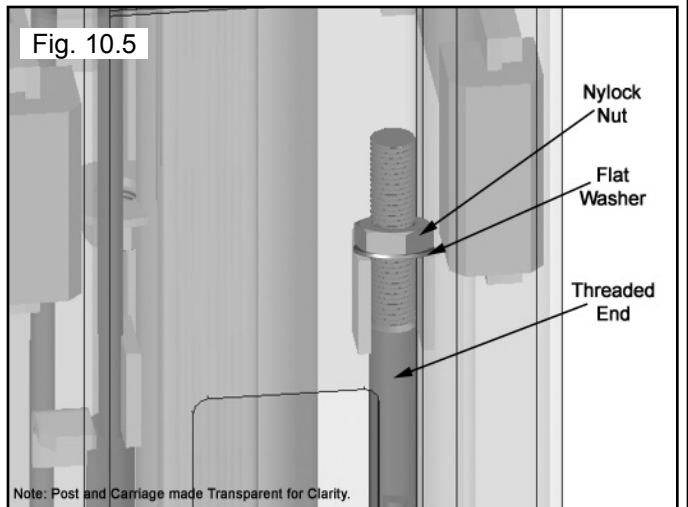

7. Reinstall the Pulleys, Bottom Sheave Covers and Hair Pins.

8. Repeat the procedure for the other Equalizer Cable.

STEP 11

(Installing Powerside and Offside Safety Cover)

1. After Safeties have been adjusted and checked for proper operation, install and tighten Powerside Safety Cover and Offside Safety Cover mounting Bolts. (See Fig. 11.1 and 11.2)

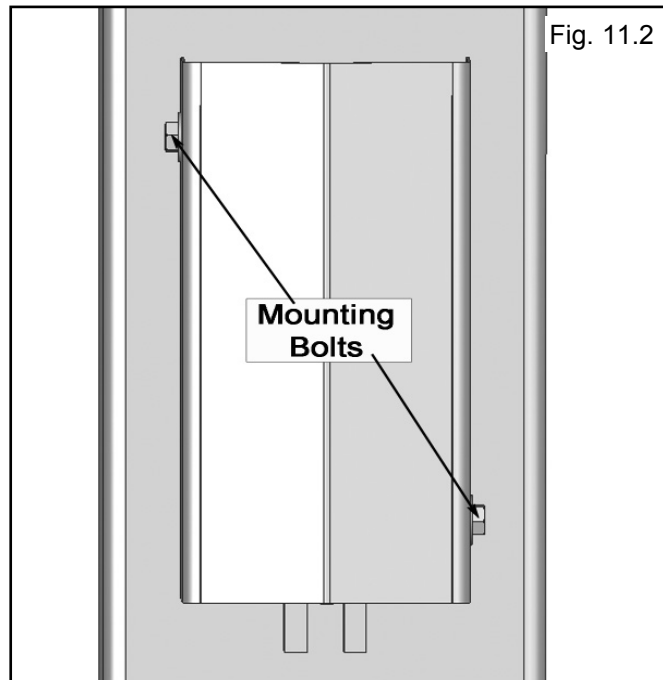
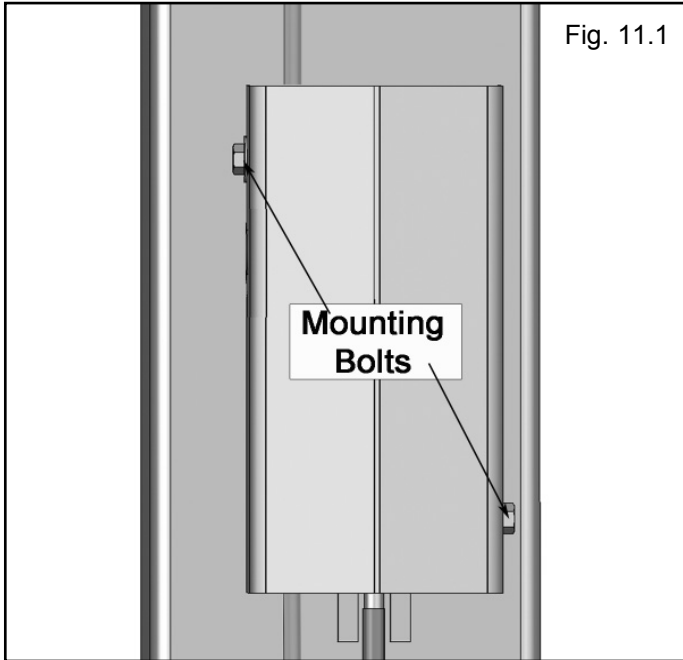

THIS
SPACE
INTENTIONALLY
LEFT
BLANK

STEP 12

(Installing the Lift Arms)

1. Place the appropriate Lift Arm Assy on the Lift Heads. (See Fig. 12.3- 12.4)

2. Install the Left Head pins into the Lift Head and through the holes in the Arm Assy. (See Fig. 12.1)

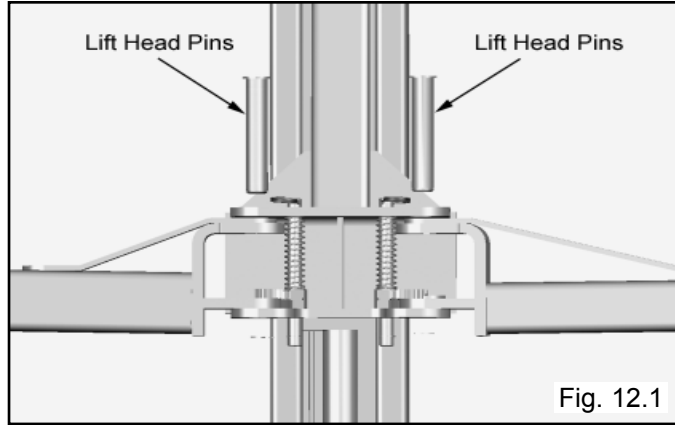

3. Install the Snap Ring into the groove in the Lift Head Pin the under side of the Lift Head. (See Fig. 12.2)

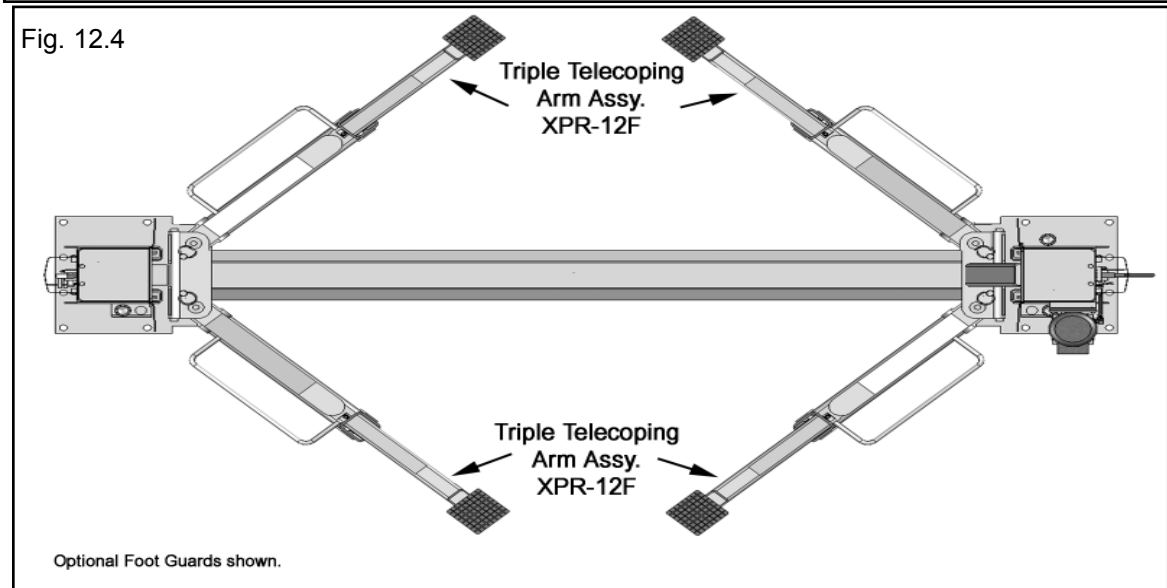
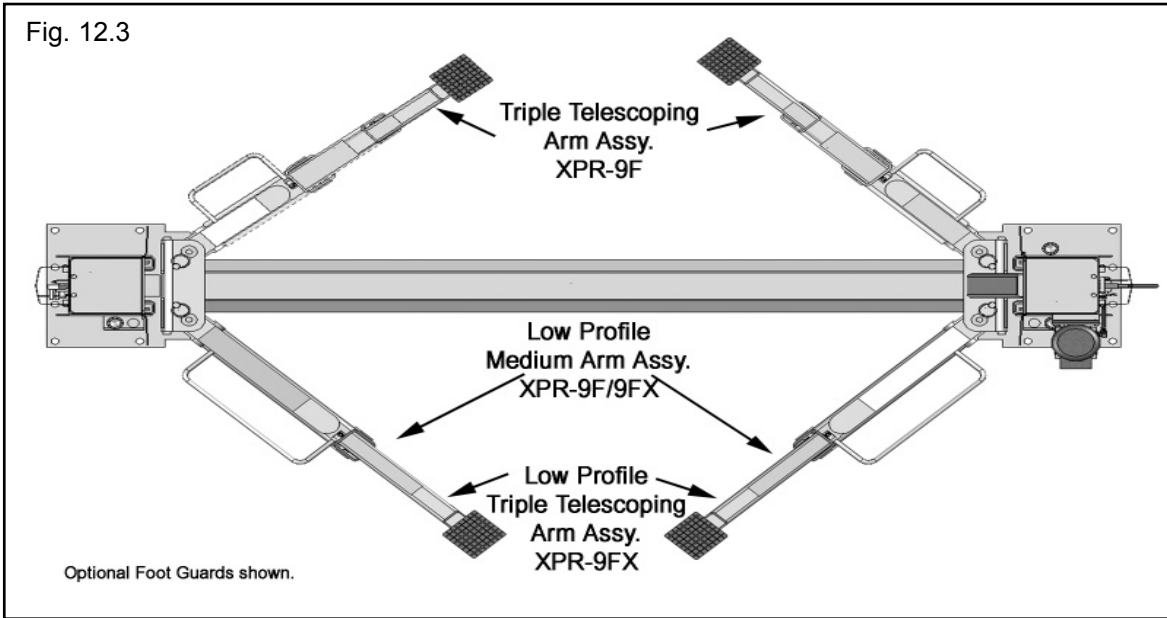
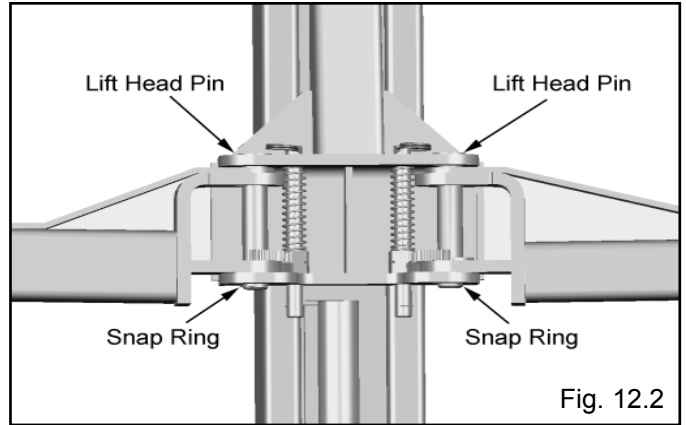

WARNING

IMPORTANT LEVELING INSTRUCTIONS

Before operating your lift, check to make sure that both "A" and "B" measurements are EQUAL.

The lift arms must be level before operation.

If your lift arms are not level, shim the columns as required.

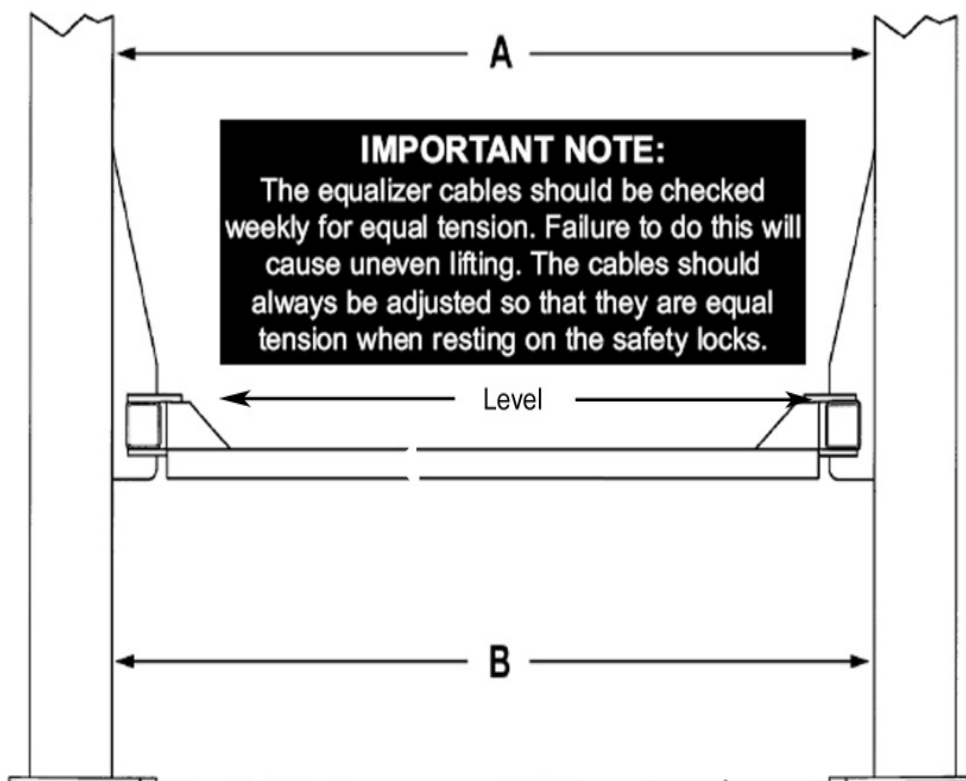

⚠ WARNING

You **MUST** re-install top Carriage-Stop Bolt (shown below) after top beam/plate is installed and secured. Tighten carriage-stop bolt to 2-3 ft. lbs. of torque upon final installation inspection. These instructions must be followed to insure proper installation and operation of your lift. Failure to comply with these instructions can result in serious bodily injury and or death and or void product warranty. Manufacturer will assume no liability for loss or damage of any kind, expressed or implied resulting from improper installation or use of this product.

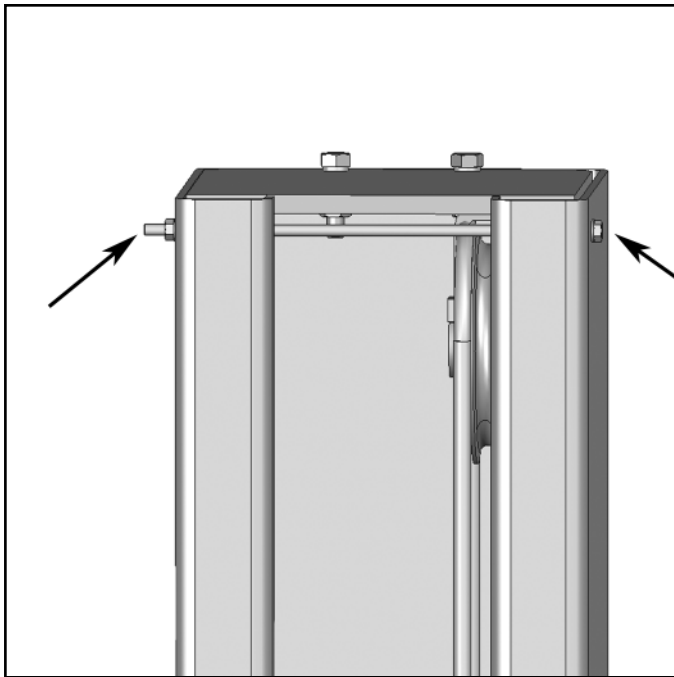
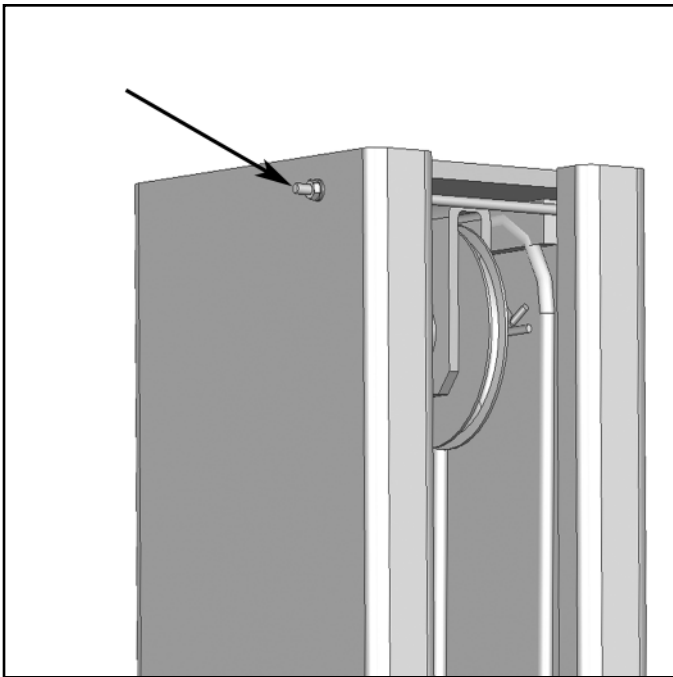
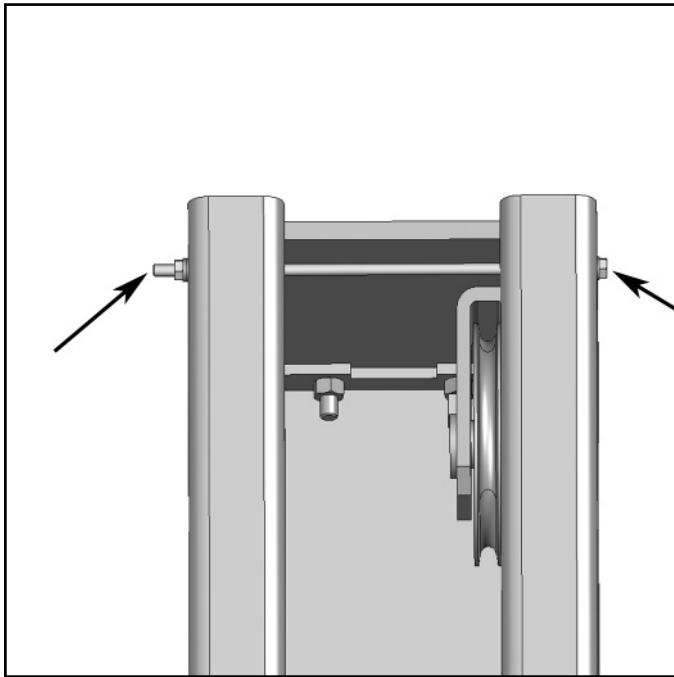
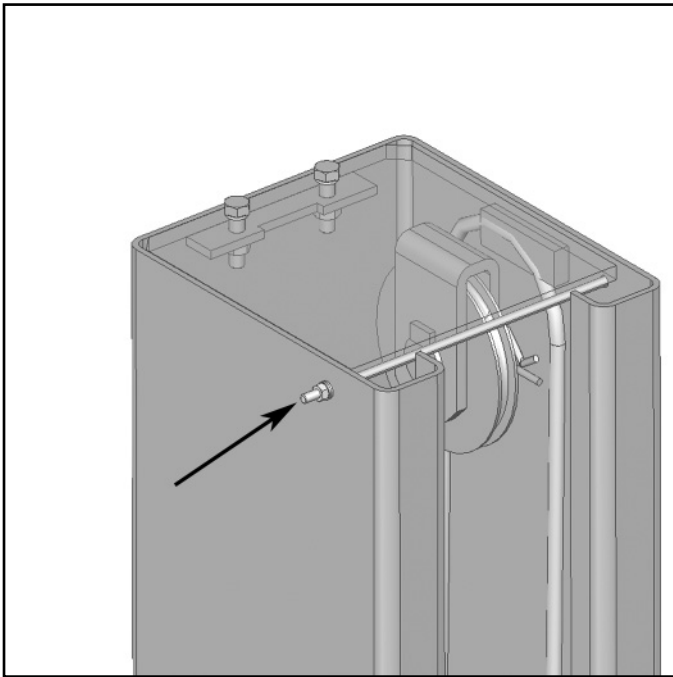



DANGER!

DO NOT PERFORM ANY MAINTENANCE OR INSTALLATION OF ANY COMPONENTS WITH OUT FIRST ENSURING THAT ELECTRICAL POWER HAS BEEN DISCONNECTED AT THE SOURCE OR PANEL AND CANNOT BE RE-ENERGIZED UNTIL ALL MAINTENANCE AND/OR INSTALLATION PROCEDURES ARE COMPLETED.



IMPORTANT POWER-UNIT INSTALLATION NOTES

- DO NOT run power unit with no oil. Damage to pump can occur.
- The power unit must be kept dry. Damage to power unit caused by water or other liquids such as detergents, acid etc., is not covered under warranty.
- Improper electrical hook-up can damage motor and will not be covered under warranty.
- Motor can not run on 50HZ without a physical change in motor.
- Use a separate breaker for each power unit.
- Protect each circuit with time delay fuse or circuit breaker.
- For 208-230 volt, single phase, use a 25 amp fuse.
- For 208-230 volt, three phase, use a 20 amp fuse.
- For 380-440 volt, three phase, use a 15 amp fuse.

Installation and adjustment.

DO NOT attempt to raise vehicle until a thorough operation check has been completed.

All wiring must be performed by a certified electrician only.

Single Phase

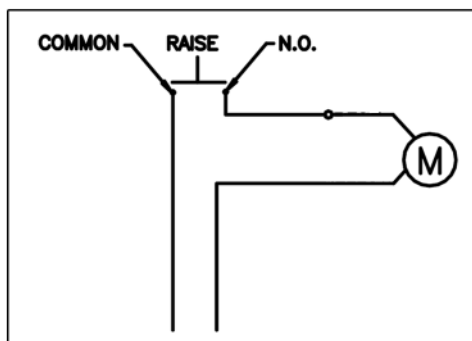

Three Phase

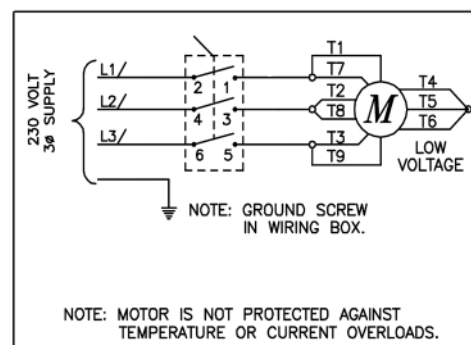

SEE WIRING INSTRUCTIONS AFFIXED TO MOTOR FOR PROPER WIRING INSTRUCTIONS.

STEP 13

(Power Unit Hook Up)

1. Have a certified electrician run the power supply to motor. Refer to the data plate found on the motor for proper power supply and wire size.



RISK OF EXPLOSION!

This equipment has internal arcing or parts that may spark and should not be exposed to flammable vapors. Motor should not be located in a recessed area or below floor level. NEVER expose motor to rain or other damp environments. DAMAGE TO MOTOR CAUSED BY WATER IS NOT COVERED UNDER WARRANTY.

IMPORTANT NOTE:

CAUTION Never operate the motor on line voltage less than 208V. Motor damage may occur which is not covered under warranty. Have a certified electrician run appropriate power supply to motor. Size wire for 25 amp circuit. See Motor Operating Data Table.

IMPORTANT: Use separate circuit for each power unit.

Protect each circuit with time delay fuse or circuit breaker. For single phase 208-230V, use 25 amp fuse. Three phase 208-240V, use 25 amp fuse. For three phase 400V and above, use 15 amp fuse. All wiring must comply with NECK and all local electrical codes.

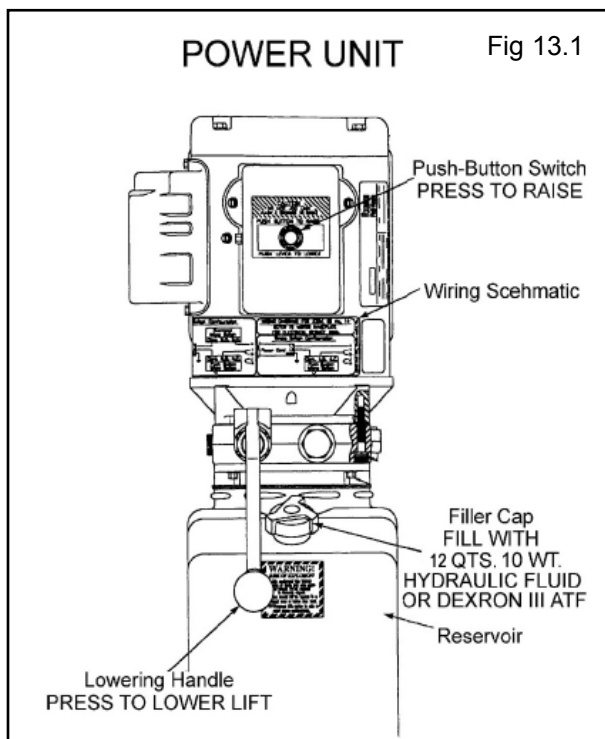

Typical Power Unit shown, control and labels may vary

STEP 14

(Lift Start Up / Final Adjustments)



CAUTION!

During the START-UP procedure, observe all operating components and check for proper installation and adjustment. DO NOT attempt to raise vehicle until a thorough operational check has been completed.

1. Make sure the Power Unit reservoir is full with 12 quarts of 10-WT hydraulic oil or Dexron-III automatic transmission fluid.
2. Spray the inside of the Columns where the Slide Blocks glide with a light lubricant or WD-40.
3. Test the Power Unit by pressing the push-button switch. If the motor sounds like it is operating properly, raise the lift and check all hose connections for leaks. If the motor gets hot or sounds peculiar, stop and check all electrical connections.
4. Before proceeding, double-check to make sure all Cables are properly positioned within the grooves of ALL Sheaves/Pulleys. Make sure all Cable Sheave retaining Pins and/or Clips are secure.
5. Check to make sure that all Safety Locks are cleared and free.
6. Continue pressing the raise button until the Cables get taut and the lift starts to move.
8. **KEEP HANDS AND FEET CLEAR.** Remove hands and feet from any moving parts. Keep feet clear of lift when lowering. Avoid pinch points.
9. Check all MAIN SAFETY LOCKS to make sure they move freely and spring back to the lock position when released. Lubricate all SAFETY PIVOT points with WD-40 or equal.
10. Run the lift up and down a few times to insure that the locks are engaging uniformly and that the safety release mechanisms are functioning. Re-adjust if necessary.

POST-INSTALLATION CHECK-OFF

- Columns Properly Shimmed And Stable
- Anchor Bolts Tightened
- Pivot / Sheave Pins Properly Attached
- Carriage Stop bolts Torqued to 2-3 Ft. Lbs
- Electric Power Supply Confirmed
- Cables Adjusted Properly
- Safety Locks Functioning Properly
- Check For Hydraulic Leaks
- Oil Level
- Lubrication of Critical Components
- Check For Overhead Obstructions
- Lift Arms Level
- All Screws, Bolts, and Pins Secured
- Surrounding Area Clean
- Operation, Maintenance and Safety Manuals on Site.

NOTE:

There will be initial stretching of the cables and/or with increased loads. Adjust the cables as outlined above a week after first use, then every three to six months thereafter depending on usage and/or to compensate for stretch.

STEP 15

(Lubrication)

1. After installation and start up has been completed, lubricate lift components as described below.

(See Fig. 15.1)

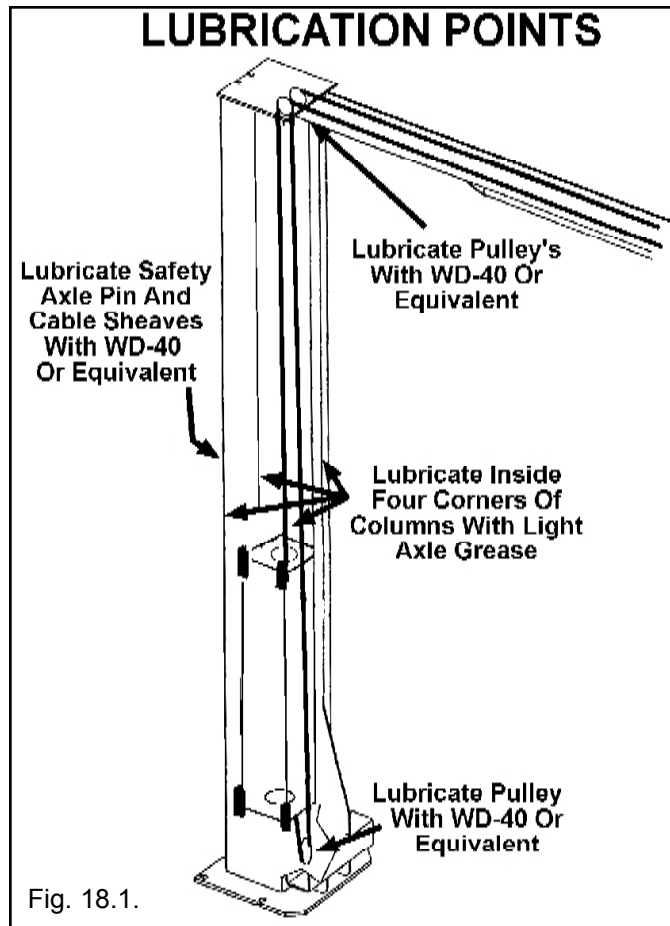

OPTIONAL EQUIPMENT INSTALLATION

Utility Air-Electric Workstation

Utility Station may be mounted on the vertical column of the lift or on a wall.

IMPORTANT: Check State or Local codes for any height requirements for the electrical outlets before mounting.

To mount the Utility Station on a Lift Column, use the Box as a template, mark and drill 11/32" diameter holes. Use 5/16" diameter bolts and lock nuts to secure to the side of the lift.

IMPORTANT: The hole locations are critical to avoid interference with the carriage slide blocks.

For Wall mounting, mount in the same fashion, use appropriate hardware for either sheet rock or concrete.

IMPORTANT: All electrical wiring shall comply with all State and Local Codes.

Connect electrical wiring to single phase, 60Hz 115 volt electrical supply using suitable conduit (not supplied). The duplex receptacle must be connected through the GFCI with the input line to the box connected to a circuit breaker or time delay fuse rated at 20 amps. Both receptacles must be grounded to the box.

Connect main air supply to 1/4" ball valve inlet on the Utility Station (Run 1/2" line from compressor or main air system to Utility Station.)

Install Quick Couplers to the 1/4" male fittings on the box. The air supply between the filter and the lubricator will be non-lubricated, used for tire inflation or blowing off. The air outlet on the left side will be lubricated for air tool use.

Regulator Instructions

- Regulate pressure by raising the knob, then turning clockwise to increase and counterclockwise to decrease. Push knob down to lock setting.
- Adjust the oil mist using the screwdriver slot located on top of the lubricator.
- To fill the lubricator, first depressurize the air system, remove the slotted screw plug in the body. Replace the screw before repressurizing.

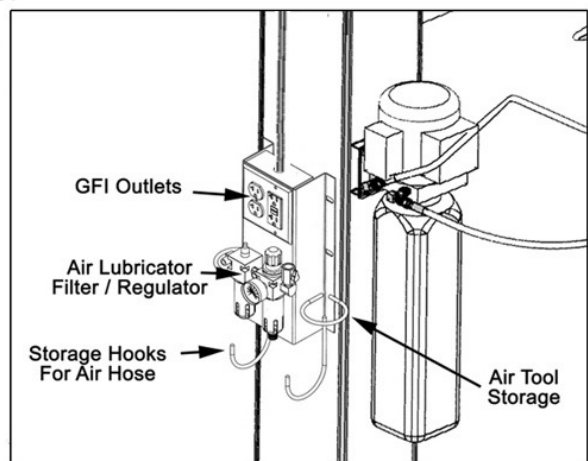
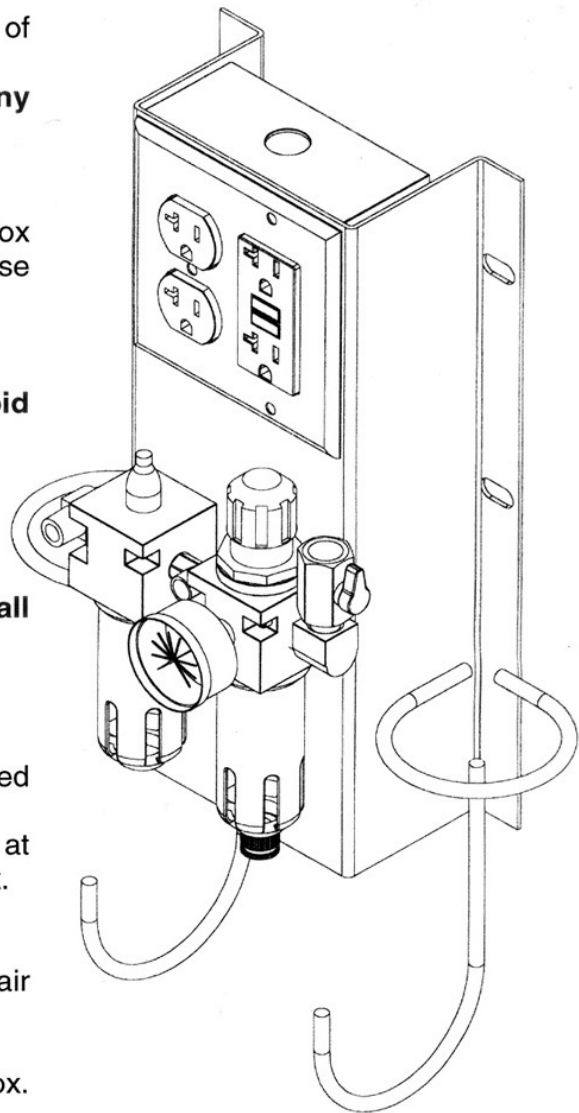

OPTIONAL FOOT GUARD INSTALLATION

1. Install the Foot Guards to the outside of the 4 Lift Arm Assemblies. Tighten the Hex Head Bolts. (See Fig 1-2)

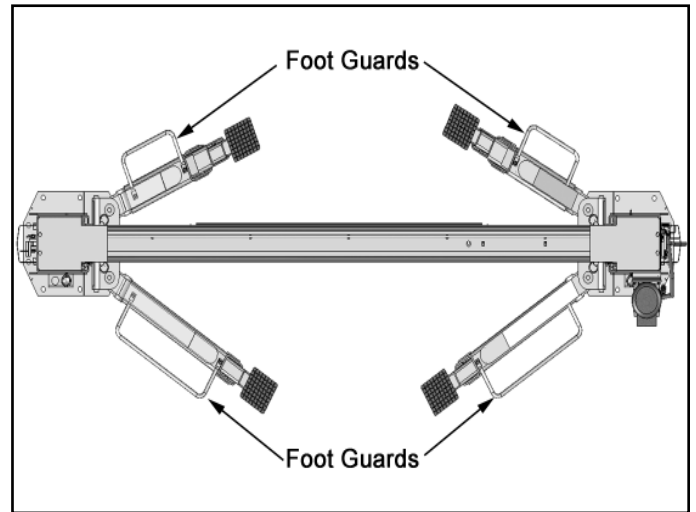
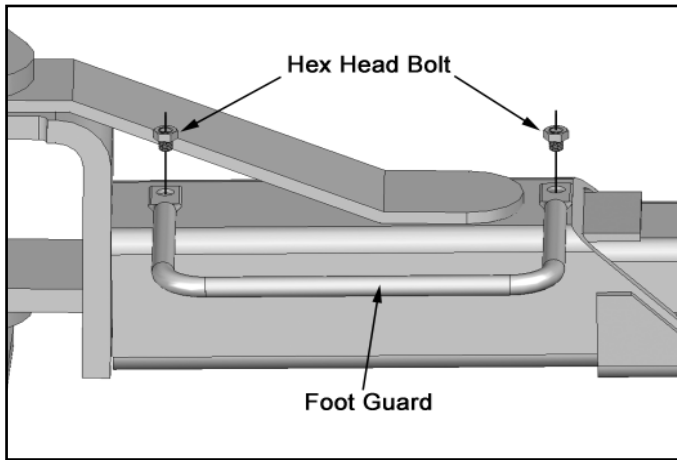

OPTIONAL CRADLE AND SCREW PAD ADAPTERS

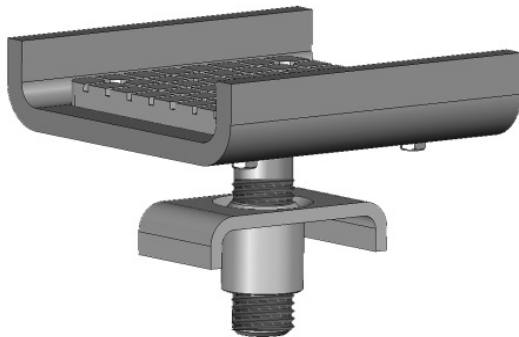

Adjustable Frame Cradle Pads

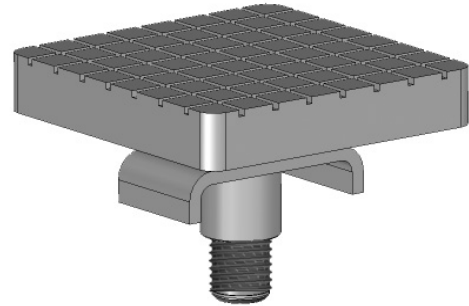

Screw Pad Adapter



Frame Cradle Pad



Adjustable Extension Adapters

Optional Equipment available through your Authorized BendPak Dealer.

STEP 16

(Operation)

To Raise Lift;

1. Load vehicle onto the lift using Vehicle Lifting Guide to determine proper lifting points.

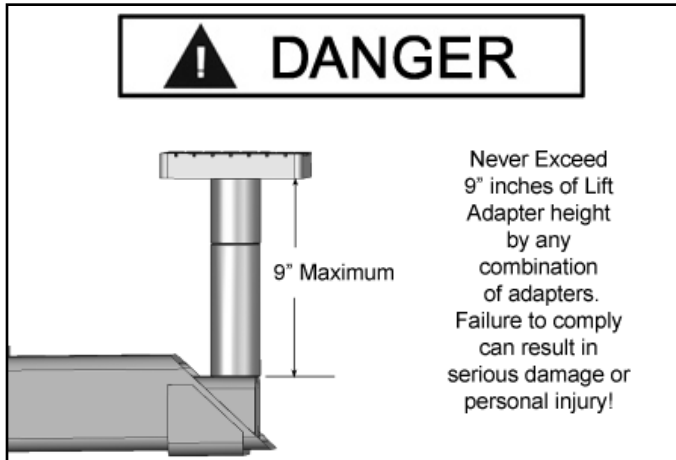

2. **NEVER** use lift pad assemblies without rubber slip over pads in place.
3. Set parking brake or use wheel chock to hold vehicle in position.
4. Before raising vehicle, be sure all personnel are clear of the lift and surrounding area. Pay careful attention to overhead clearances.
5. Raise the lift to the desired height by pressing the push button on the power unit.



VISUALLY CONFIRM THAT ALL PRIMARY SAFETY LOCKS ARE ENGAGED BEFORE ENTERING WORK AREA.

Suspension components on this lift are intended to raise and lower lift only and are not meant to be load holding devices. Remain clear of elevated lift unless visual confirmation is made that all primary safety locks are fully engaged and the lift is LOWERED onto the safety locks. Refer to installation /operation manual for proper safety lock procedures and /or further instruction.

6. After vehicle is raised to the desired height, **lower the lift onto the nearest safety lock.** Do not allow cables to become slack. **ALWAYS INSURE ALL SAFETY LOCKS ARE ENGAGED** before entering work area.

To Lower Lift;

1. Before lowering vehicle, be sure all personnel are clear of the lift and surrounding area. Pay careful attention to overhead clearances. Insure all tools and equipment have been cleared from under the lift.
2. Raise the lift off of the safety locks by pressing the push button on the power unit. Make sure you raise the lift by at least two inches to allow adequate clearance for the locks to clear.
3. Press the push button air safety valve and HOLD.
4. Push the LOWERING HANDLE on the power unit until the lift has descended completely.

When lowering the lift **PAY CAREFUL ATTENTION** that all personnel and objects are kept clear. **ALWAYS** keep a visual line of site on the lift **AT ALL TIMES.** **ALWAYS** make sure that **ALL LOCKS** are disengaged. If one of the locks inadvertently locks on descent the lift and/or vehicle may disrupt causing personal injury or death,

WEEKLY MAINTENANCE

1. Lubricate all rollers with general purpose oil or WD-40.
2. Check all cable connections, bolts and pins to insure proper mounting.
3. Lubricate safety lock pivot points with general purpose oil or WD-40.

MONTHLY MAINTENANCE

1. Check safety locks to insure they are in good operating condition.
2. Check all cables for excessive signs of wear.
3. Make a visual inspection of ALL MOVING PARTS and check for excessive signs of wear.
4. Replace ALL FAULTY PARTS before lift is put back into operation.



- ◆ **NEVER EXCEED THE RATED CAPACITY** of lift.
- ◆ **DO NOT USE LIFT** if any component is found to be defective or worn.
- ◆ **NEVER OPERATE LIFT** with any person or equipment below.
- ◆ **ALWAYS STAND CLEAR** of lift when lowering or raising.
- ◆ **ALWAYS INSURE SAFETY LOCKS ARE ENGAGED** before entering work area.
- ◆ **NEVER LEAVE LIFT IN ELEVATED CONDITION** unless all safety locks are engaged.

TO RAISE LIFT

- ◆ Read operating and Safety manuals before using lift.
- ◆ Always lift a vehicle according to the manufactures recommended lifting points.
- ◆ Position vehicle between columns.
- ◆ Adjust swing arms so that the vehicle is positioned with the center of gravity midway between pads.
- ◆ Use truck adapters as needed. never exceed 9" of Pad height.
- ◆ **NEVER** use lift pad assemblies without rubber slip over pads in place.
- ◆ Raise the vehicle by depressing button until the vehicle just lifts off the ground. Recheck to make sure the vehicle is secure and all locking pins are lock in place.
- ◆ Raise vehicle to desired height. Lower vehicle onto nearest safety,
- ◆ Always ensure safeties are engaged before any attempt is made to work on or near vehicle.

TO LOWER THE LIFT

- ◆ First raise the lift clear to the safeties.
- ◆ Release safeties by pulling on the safety handle.
- ◆ Be sure tool trays, stands or personnel are cleared from under the vehicle.
- ◆ Lower vehicle by activating lowering handle on power unit.
- ◆ Before removing vehicle from lift; position lift arms and supports to provide an unobstructed exit.
- ◆ **NEVER**, drive over lift arms.

REQUIRED MONTHLY MAINTENANCE

- ◆ Check all arm adjusting locks for proper operation.
- ◆ Check all cables connections, bolts and pins to insure proper mounting and torque.
- ◆ Visually inspect safeties for proper operation.
- ◆ Lubricate columns with grease.
- ◆ Inspect all anchors bolts and retighten if necessary.
- ◆ Check all columns for squareness and plumb.
- ◆ Inspect all pivot arms pins making sure they are properly secure.
- ◆ Check equalizer cable tension, and adjust if necessary.
- ◆ If lift is equipped with over head cut-off switch, check for proper operation.



1. **WARNING!** If cement anchor bolts are loose or any component of the lift is found to be defective, **DO NOT USE THE LIFT!!**
2. Never operate the lift with any person or equipment below the vehicle.
3. Never exceed the rated lift capacity.
4. Always insure the safeties are engaged before any attempt is made to work on or near the vehicle.
5. Never leave lift in elevated position unless the safeties are engaged.
6. Do not permit electric motor to get wet! Motor damage caused by dampness is not covered under warranty.



NEVER LIFT ANY VEHICLE IN ANY MANNER WITH LESS THE ALL FOUR (4) ARMS. RATED CAPACITY OF EACH LIFT ARM IS NO GREATER THAT ONE FOURTH (1/4) OF THE OVERALL LIFT CAPACITY.



WIRE ROPE INSPECTION AND MAINTENANCE

◆ Lifting cables should be replaced every three - five years or when visible signs of damage are apparent. **DO NOT USE LIFT WITH DEFECTIVE / WORN CABLES.**

◆ Lifting cables should be maintained in a well-lubricated condition at all times. Wire rope is only fully protected when each wire strand is lubricated both internal and external. Excessive wear will shorten the life of the wire rope. The factory suggested wire rope lubricant that penetrates to the core of the rope and provides long-term lubrication between each individual strand is 90-WT gear oil or ALMASOL® Wire Rope Lubricant. In order to make sure that the inner layers of the rope remain well lubricated, lubrication should be carried out at intervals not exceeding three months during operation.

◆ All sheaves and guide rollers in contact with the moving rope should be given regular visual checks for surface wear and lubricated to make sure that they run freely. This operation should be carried out at appropriate intervals generally not exceeding three months during operation. For all sheave axles, the factory recommends standard wheel bearing grease. For all sheaves and/or guide rollers, the factory recommends 90-WT gear oil or similar heavy lubricant applied by any method including pump / spray dispensing, brush, hand and/or swabbing.

HOW OFTEN TO INSPECT

◆ Lifting cables should be visually inspected at least once each day when in use, as suggested by American Petroleum Institute (API) RP54 guidelines.

◆ Any lifting cables that have met the criteria for removal must be immediately replaced.

WHEN TO REPLACE LIFTING CABLES DUE TO BROKEN WIRES

◆ Lifting cables should be removed from service when you see six randomly distributed broken wires within any one lay length, or three broken wires in one strand within one lay length.

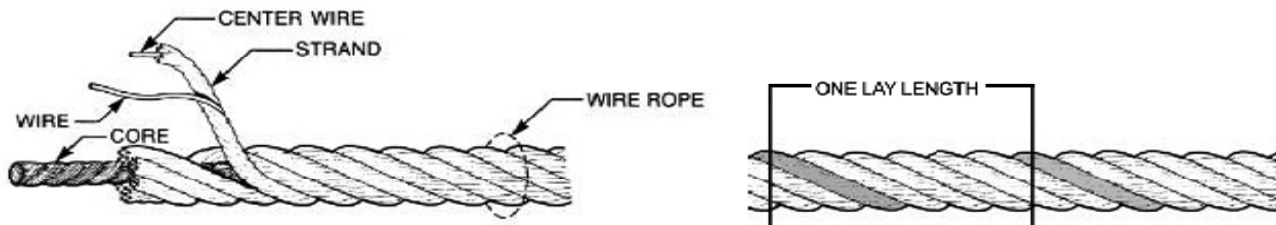

The three basic components of a typical wire rope.

OTHER REASONS TO REPLACE LIFTING CABLES

- ◆ Corrosion that pits the wires and/or connectors.
- ◆ Evidence of kinking, crushing, cutting, bird-caging or a popped core.
- ◆ Wear that exceeds 10% of a wire's original diameter.
- ◆ Evidence of heat damage.

HOW TO FIND BROKEN WIRES

◆ The first step is to relax your rope to a stationary position and move the pick-up points off the sheaves. Clean the surface of the rope with a cloth — a wire brush, if necessary — so you can see any breaks.

◆ Flex the rope to expose any broken wires hidden in the valleys between the strands.

◆ Visually check for any broken wires. One way to check for crown breaks is to run a cloth along the rope to check for possible snags.

◆ With an awl, probe between wires and strands and lift any wires that appear loose. Evidence of internal broken wires may require a more extensive rope examination.

⚠ WARNING

WIRE ROPE INSPECTION AND MAINTENANCE

- Lifting cables should be replaced every three years or when visible signs of damage are apparent. **DO NOT USE LIFT WITH DEFECTIVE / WORN CABLES.**
- Wire rope should be maintained in a well-lubricated condition at all times. Wire rope is only fully protected when each wire strand is lubricated both internal and external. Excessive wear will shorten the life of the wire rope. The factory suggested wire rope lubricant that penetrates to the core of the rope and provides long term lubrication between each individual strand is AMSOIL Synthetic Open Gear and Wire Rope Compound or 90-W1 gear oil or similar heavy lubricant. In order to make sure that the inner layers of the rope remain well lubricated, lubrication should be carried out at intervals not exceeding three months during operation.
- All sheaves and guide rollers in contact with the moving rope should be given regular visual checks for surface wear and lubricated to make sure that they run freely. This operation should be carried out at appropriate intervals generally not exceeding three months during operation. For all sheave axles, the factory recommends standard wheel bearing grease. For all sheaves and/or guide rollers, the factory recommends 90-W1 gear oil or similar heavy lubricant applied by any method including pump / spray dispensing, brush, hand and/or swabbing.

**Failure to read, understand, and follow these instructions may cause death or serious injury.
Read and understand these instructions before using lift.**

SAFETY INSTRUCTIONS



Read operating and safety manuals before using lift.

©

SAFETY INSTRUCTIONS



Proper maintenance and inspection is necessary for safe operation.

©

SAFETY INSTRUCTIONS



Do not operate a damaged lift.

©

The messages and pictographs shown are generic in nature and are meant to generally represent hazards common to all automotive lifts regardless of specific style

Funding for the development and validation of these labels was provided by the Automotive Lift Institute, PO Box 33116 Indianalantic, FL 32903

They are protected by copyright
Set of labels may be obtained from
ALI or its member companies

© 1992 by ALI, Inc

ALI/WL1018



CAUTION
Lift to be used by trained operator only.

©



CAUTION
Authorized personnel only in lift area.

©



WARNING
Clear area if vehicle is in danger of falling.

©



WARNING
Position vehicle with center of gravity midway between adapters.

©

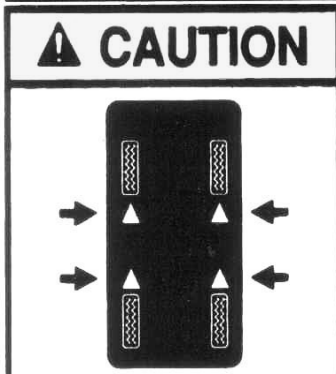

CAUTION
Use vehicle manufacturer's lift points.

©



CAUTION
Always use safety stands when removing or installing heavy components.

©



WARNING
Remain clear of lift when raising or lowering vehicle.

©



WARNING
Avoid excessive rocking of vehicle while on lift.

©



CAUTION
Use height extenders when necessary to ensure good contact.

©



CAUTION
Auxiliary adapters may reduce load capacity.

©



WARNING
Do not override self-closing lift controls.

©



WARNING
Keep feet clear of lift while lowering.

©

The messages and pictographs shown are generic in nature and are meant to generally represent hazards common to all automotive lifts regardless of specific style.

Funding for the development and validation of these labels was provided by the Automotive Lift Institute, PO Box 33116 Indialantic, FL. 32903.

They are protected by copyright. Set of labels may be obtained from ALI or its member companies.

© 1992 by ALI, Inc.

ALI/WL101c

The messages and pictographs shown are generic in nature and are meant to generally represent hazards common to all automotive lifts regardless of specific style.

Funding for the development and validation of these labels was provided by the Automotive Lift Institute, PO Box 33116 Indialantic, FL. 32903.

They are protected by copyright. Set of labels may be obtained from ALI or its member companies.

© 1992 by ALI, Inc.

ALI/WL101w

Safe Lift Operation

Automotive and truck lifts are critical to the operation and profitability of your business. The safe use of this and other lifts in your shop is critical in preventing employee injuries and damage to customer's vehicles. By operating lifts safely you can insure that your shop is profitable, productive and safe.

Safe operation of automotive lifts requires that only trained employees should be allowed to use the lift.

TRAINING SHOULD INCLUDE, BUT NOT LIMITED TO:

- ◆ Proper positioning of the vehicle on the runway. (See manufacturers minimize wheel base loading requirements.)
- ◆ Use of the operating controls.
- ◆ Understanding the lift capacity.
- ◆ Proper use of jack stands or other load supporting devices.
- ◆ Proper use, understanding and visual identification of safety lock devices and their operation.
- ◆ Reviewing the safety rules.
- ◆ Proper housekeeping procedures (lift area should be free of grease, oil, tools, equipment, trash, and other debris)
- ◆ A daily inspection of the lift should be completed prior to its use. Safety devices, operating controls, lift arms and other critical parts should be inspected prior to using the lift.
- ◆ All maintenance and repairs of the lift should be completed by following the manufacturer's requirements. Lift repair parts should meet or exceed OEM specifications. Repairs should only be completed by a qualified lift technician.
- ◆ The vehicle manufacturer's recommendations should be used for spotting and lifting the vehicle.

LIFT OPERATION SAFETY

- ◆ It is important that you know the load limit. Be careful that you do not overload the lift. If you are unsure what the load limit is, check the data plate found on one of the lift columns or contact the manufacturer.
- ◆ The center of gravity should be followed closely to what the manufacturer recommends.
- ◆ Always make sure you have proper overhead clearance. Additionally, check that attachments, (vehicle signs, campers, antennas, etc.) are not in the way.
- ◆ Be sure that prior to the vehicle being raised, the doors, trunk, and hood are closed securely.
- ◆ Prior to being raised, make sure there is no one standing closer than six feet from the lift.
- ◆ After positioning the vehicle on the lift runways, set the emergency brake, make sure the ignition is off, the doors are closed, overhead obstructions are cleared, and the transmission is in neutral.
- ◆ Double check that the automatic chock devices are in position and then when the lift is raised, observe the chocks.
- ◆ Put pads or adapters in the right position under the contact points that have been recommended.
- ◆ The lift should be raised just until the vehicle's wheels are about one foot off the ground. If contact with the vehicle is uneven or it appears that the vehicle is not sitting secure, carefully lower the lift and readjust.
- ◆ Always consider potential problems that might cause a vehicle to slip, i.e., heavy cargo, undercoating, etc.
- ◆ Pay attention when walking under a vehicle that is up on the hydraulic lift.



- ◆ **DO NOT** leave the controls while the lift is still in motion.
- ◆ **DO NOT** stand directly in front of the vehicle or in the bay when vehicle is being loaded or driven into position.
- ◆ **DO NOT** go near vehicle or attempt to work on the vehicle when being raised or lowered.
- ◆ **REMAIN CLEAR** of lift when raising or lowering vehicle.
- ◆ **DO NOT** rock the vehicle while on the lift or remove any heavy component from vehicle that may cause excessive weight shift.
- ◆ **DO NOT** lower the vehicle until people, materials, and tools are clear
- ◆ **ALWAYS INSURE** that the safeties are engaged and lowered on to the safety ladders before any attempt is made to work on or near vehicle.
- ◆ Some vehicle maintenance and repair activities may cause the vehicle to shift. Follow the manufacturer's guidelines when performing these operations. The use of jack stands or alternate lift points may be required when completing some repairs.
- ◆ **READ AND UNDERSTAND** all safety warning procedures before operating lift.
- ◆ **KEEP HANDS AND FEET CLEAR.** Remove hands and feet from any moving parts. Keep feet clear of lift when lowering. Avoid pinch points.
- ◆ **ONLY TRAINED OPERATORS** should operate this lift. All non-trained personnel should be kept away from work area. Never let non-trained personnel come in contact with, or operate lift.
- ◆ **USE LIFT CORRECTLY.** Use lift in the proper manner. Never use lifting adapters other than what is approved by the manufacturer.
- ◆ **DO NOT** override self-closing lift controls.
- ◆ **CLEAR AREA** if vehicle is on danger of falling.
- ◆ **STAY ALERT.** Watch what you are doing. Use common sense. Be aware.
- ◆ **CHECK FOR DAMAGED PARTS.** Check for alignment of moving parts, breakage of parts or any condition that may affect its operation. Do not use lift if any component is broken or damaged.
- ◆ **NEVER** remove safety related components from the lift. Do not use lift if safety related components are damaged or missing.
- ◆ When the lift is being lowered, make sure everyone is standing at least six feet away.
- ◆ Be sure there are no jacks, tools, equipment, left under the lift before lowering.
- ◆ Always lower the vehicle down slowly and smoothly.

LIFT WILL NOT RAISE

POSSIBLE CAUSE

1. Air in oil, (1,2,8,13)
2. Cylinder binding, (9)
3. Cylinder leaks internally, (9)
4. Motor run backward under pressure, (11)
5. Lowering valve leaks, (3,4,6,10,11)
6. Motor runs backwards, (7,14,11)
7. Pump damaged, (10,11)
8. Pump won't prime, (1,8,13,14,3,12,10,11)
9. Relief valve leaks, (10,11)
10. Voltage to motor incorrect, (7,14,11)

REMEDY

INSTRUCTION

- | | |
|---|--|
| 1. Check for proper oil level. | The oil level should be up to the bleed screw in the reservoir with the lift all the way down. |
| 2. Bleed cylinders. | See Installation Manual |
| 3. Flush- Release valve to get rid of. possible contamination | Hold release handle down and start unit allowing it to run for 15 seconds. |
| 4. Dirty oil. | Replace oil with clean Dexron ATF. |
| 5. Tighten all fasteners. | Tighten fasteners to recommended torques. |
| 6. Check for free movement of release. | If handle does not move freely, replace bracket or handle assembly. |
| 7. Check motor is wired correctly. | Compare wiring of motor to electrical diagram on drawing. |
| 8. Oil seal damaged or cocked | .Replace oil seal around pump shaft. |
| 9. See Installation Manual | Consult Lift Manufacturer. |
| 10. Replace with new part | Replace with new part. |
| 11. Return unit for repair | Return unit for repair. |
| 12. Check pump-mounting bolts | Bolts should be 15 to 18 ft. lbs. |
| 13. Inlet screen clogged | Clean inlet screen or replace. |
| 14. Check wall outlet voltages and wiring | .Make sure unit and wall outlet are wired properly. |

MOTOR WILL NOT RUN

POSSIBLE CAUSE

1. Fuse blown, (5,2,1,3,4)
2. Limit switch burned out, (1,2,3,4)
3. Microswitch burned out, (1,2,3,4)
4. Motor burned out, (1,2,3,4,6)
5. Voltage to motor incorrect, (2,1,8)

REMEDY

- | REMEDY | INSTRUCTION |
|---|--|
| 1. Check for correct voltage | .Compare supply voltage with voltage on motor nametag. Check that the wire is sized correctly. N.E.C. table 310-12 requires AWG 10 for 25 Amps. |
| 2. Check motor is wired correctly | .Compare wiring of motor to electrical diagram on drawing. |
| 3. Don't use extension cords | .According to N.E.C. : " The size of the conductors... should be such that the voltage drop would not exceed 3% to the farthest outlet for power..." Do not run motor at 115 VAC – damage to the motor will occur. |
| 4. Replace with new part | .Replace with new part. |
| 5. Reset circuit breaker/fuse | .Reset circuit breaker/fuse. |
| 6. Return unit for repair | Return unit for repair. |
| 7. See Installation Manual | .See Installation Manual. |
| 8. Check wall outlet voltage and wiring | Make sure unit and wall outlet is wired properly. Motor must run at 208/230 VAC. |

LIFT LOWERS SLOWLY OR NOT AT ALL

POSSIBLE CAUSE

1. Cylinders binding, (1)
2. Release valve clogged, (5,4,2,3)
3. Pressure fitting too long, (6)

REMEDY

- | REMEDY | INSTRUCTION |
|---|--|
| 1. See Installation Manual | .Consult Lift Manufacturer. |
| 2. Replace with new part | .Replace with new part. |
| 3. Return for repair | Return for repair. |
| 4. Check oil. | Use clean 10-WT hydraulic oil or Dexron-III automatic transmission fluid only. If ATF is contaminated, replace with clean ATF and clean entire system. |
| 5. Clean release valve | Wash release valve in solvent and blow out with air. |
| 6. Replace fitting with short thread lead | Replace fitting with short thread lead. |

WILL NOT RAISE LOADED LIFT

POSSIBLE CAUSE

1. Air in oil, (1,2,3,4)
2. Cylinder binding, (5)
3. Cylinder leaks internally, (5)
4. Lift overloaded, (6,5)
5. Lowering valve leaks, (7,8,1,5,9)
6. Motor runs backwards, (10,12,9)
7. Pump damaged, (5,9)
8. Pump won't prime, (1,2,3,4,5,11,9)
9. Relief valve leaks, (8,5,9)
10. Voltage to motor incorrect, (10,12,5)

REMEDY

- | REMEDY | INSTRUCTION |
|--|--|
| 1. Check oil level | The oil level should be up to the bleed screw in the reservoir with the lift all the way down. |
| 2. Check/Tighten inlet tubes | Replace inlet hose assembly. |
| 3. Oil seal damaged or cocked | Replace oil seal and install. |
| 4. Bleed cylinders | See Installation Manual. |
| 5. See Installation Manual | Consult Lift Manufacturer. |
| 6. Check vehicle weight | Compare weight of vehicle to weight limit of the lift. |
| 7. Flush release valve | Hold release handle down and start unit allowing it to run for 15 seconds. |
| 8. Replace with new part | Replace with new part. |
| 9. Return unit for repair | Return unit for repair. |
| 10. Check motor is wired correctly | Compare wiring of motor to electrical diagram on power unit drawing. |
| 11. Inlet screen clogged | Clean inlet screen or replace. |
| 12. Check wall outlet voltage and wiring | Make sure unit and wall outlet is wired properly. |

LIFT WILL NOT STAY UP

POSSIBLE CAUSE

1. Air in oil, (1,2,3)
2. Check valve leaks, (6)
3. Cylinders leak internally, (7)
4. Lowering valve leaks, (4,5,1,7,6)
5. Leaking fittings, (8)

REMEDY

1. Check oil level The oil level should be up to the bleed screw in the reservoir with the lift all the way down.
2. Oil seal damaged and cocked Replace oil seal around pump shaft.
3. Bleed cylinder Refer to Installation Manual.
4. Flush release valve Hold release handle down and start unit allowing it to run for 15 seconds.
5. Replace with new valve Replace with new valve.
6. Return unit for repair Return unit for repair.
7. See Installation Manual Consult Lift Manufacturer.
8. Check complete hydraulic system for leaks. Tighten all hydraulics fittings and inspects all hoses.

INSTRUCTION

ITEM NO.	PART NUMBER	DESCRIPTION	QTY.	REV
1	801073	XPR-9F/FX POWER SIDE POST ASSEMBLY	1	E-001
2	800100	POWER SIDE SAFETY WELDMENT	1	PRE-004
3	800104	OFF SIDE SAFETY WELDMENT	1	PRE-004
4	800106	SLIP ON LIFT PAD ASSEMBLY	4	PRE-005
5	800112	OFF SIDE COVER	2	PRE-003
6	800124	XP-9/-10 SHEAVE ASSEMBLY	2	PRE-006
7	800191	SAFETY CLEVIS PIN	2	B
8	800207	SHORT LIFT PAD EXTENSION (113mm LG.)	4	B
9	800208	LONG LIFT PAD EXTENSION (182mm LG.)	4	PRE-008
10	FG-800295	XP-9F/FX	1	PRE-005
11	800299	OFF SIDE POST ASSEMBLY	1	PRE-004
12	800300	XP/XPR-9-F GROUND PLATE	1	PRE-004
13	800309	TOP EQUALIZER	2	PRE-004
14	800316	PULLEY PLATE WELDMENT	2	B
15	800325	XP/XPR-9-F/FX CHAIN ROLLER ASSEMBLY	2	B
16	800330	LEVELING PLUG	2	B-004
17	800335	Ø6.35 x 2985LG. POWER UNIT HYDRAULIC HOSE ASSEMBLY	1	A
18	800693	3/8-18 NPT TUBE FITTING	2	--
19	800750	Ø6.35 x 1359LG. HYDRAULIC HOSE	2	A
20	800868	XPR-9F, XP/XPR-9FD Ø2.4mm x 6858 LG. SAFETY CABLE	1	A
21	801074	LIFT HEAD PIN WELDMENT	4	B
22	801105	XPR-9F/FX LIFT HEAD ASSEMBLY	2	D-002
23	800332	Ø10mm x 9646 LG. EQUALIZER CABLE ASSEMBLY	2	C-002
24	LP-800979	POWER UNIT VIBRATION DAMPENER	1	PRE-002
25	LP-800987	XP/XPR-9F/FX CYLINDER CHAIN ASSEMBLY	2	A
26	700583	LOW PROFILE MEDIUM ARM ASSEMBLY	2	D
27	FG-801014	XPR-9F/FD/10C/AC TRIPLE TELESCOPING ARM	2	E
28	FG-801017	CYLINDER ASSEMBLY Ø 2.5 x 37	2	PRE-005
29	AB-1551 POWER UNIT	XPR-9F/FX/FD/10C/AC ARM FOOT GUARD (280mm)	2	D
30	OVAL SLEEVE	ARM FOOT GUARD (526mm)	2	D
31	WASHER	POWER UNIT	1	PRE-008
32	16 DIA. HAIRPIN COTTER	SAFETY CABLE GRIMP	1	PRE-002
33	800200	Ø25 x 13 x 1.5mm FLAT WASHER	2	--
34	HN M12x1.75	Ø3.75 x 68mm	2	--
35	HN M18 x 2.5	2.5 WIRE DIA., Ø25.5x150 LG. HEX NUT M12 x 1.75	2	PRE-004
		HEX NUT M18 x 2.5	1	--

ITEM NO.	PART NUMBER	DESCRIPTION	QTY.	REV
36	WASHER	Ø50 x 20 x 3.0mm W WASHER	1	--
37	HNB M8 x 1.25 x 25	HEX HEAD BOLT	4	--
38	8 x 15 x 2 LW	SPRING LOCK WASHER	4	--
39	HN M8 x 1.25	HEX NUT M8 x 1.25	4	--
40	HNB M10 x 1.5 x 38	HEX HEAD BOLT M10 x 1.5 x 38	4	--
41	HNB M8 x 1.25 x 18	HEX HEAD BOLT	4	--
42	HN M10 X 1.5	HEX NUT	4	--
43	10 x 18 x 2.3 LW	SPRING LOCK WASHER	4	--
44	WASHER	10 I.D. x 28 O.D. x 1.5	4	--
45	HNB M10 x 1.5 x 25	HEX HEAD BOLT	8	--
46	90.375ElbowORing	90°ELBOW, 37°MALE FLARE 9/16-18UNF-2A TO 3/8-18NPT-2A, ADJUSTABLE O-RING	1	--
47	90deg.375NPT-.44	90° ELBOW 3/8-18 NPT TO 7/16-20 UNF MALE THREAD	2	--
48	90deg.375NPT	90° ELBOW 3/8-18 NPT TO 3/8-18 NPT MALE THREAD	2	--
49	MALE .25-.4375 TEE	MALE BULKHEAD TEE 1/4"NPT-7/16-20 TO 3/8-18 NPT TO 37° FLARE 7/16-20 UNF 2B	1	--
50	90deg .25 NPT FEMALE-.4375 MALE	90° ELBOW FEMALE 1/4-18 NPT TO 37° MALE FLARE 7/16-20 UNF 2B 1 3/8" LONG	1	--
51	22 DIA. HAIRPIN COTTER	Ø4.5 x 75mm	2	--
52	P-543	XPR PLASTIC COVER BLOCK 105x80	2	A

DO NOT SCALE DRAWING		NAME		DATE	
DIMENSIONS ARE IN MM		DRAWN	TD	06/20/2007	
TOLERANCES:		CHECKED	AC	11/16/2007	
ANGULAR: MACH: 1/2°		THIRD ANGLE PROJECTION			
SURFACE FINISH					
MATERIAL: ---					
MATERIAL: ---		<p>PROPRIETARY AND CONFIDENTIAL</p> <p>THE INFORMATION CONTAINED IN THIS DRAWING IS THE PROPERTY OF BENDPAK INC. ANY REPRODUCTION IN PART OR AS A WHOLE WITHOUT THE WRITTEN PERMISSION OF BENDPAK INC. IS PROHIBITED.</p>			
SIZE: ---		TITLE: XPR-9F LIFT ASSEMBLY			
TEST ASSEMBLY: ---		SIZE DWG. NO. XPR-9-F			
		SCALE: 1:1.75			
		REV E			
		SHEET 1 OF 4			

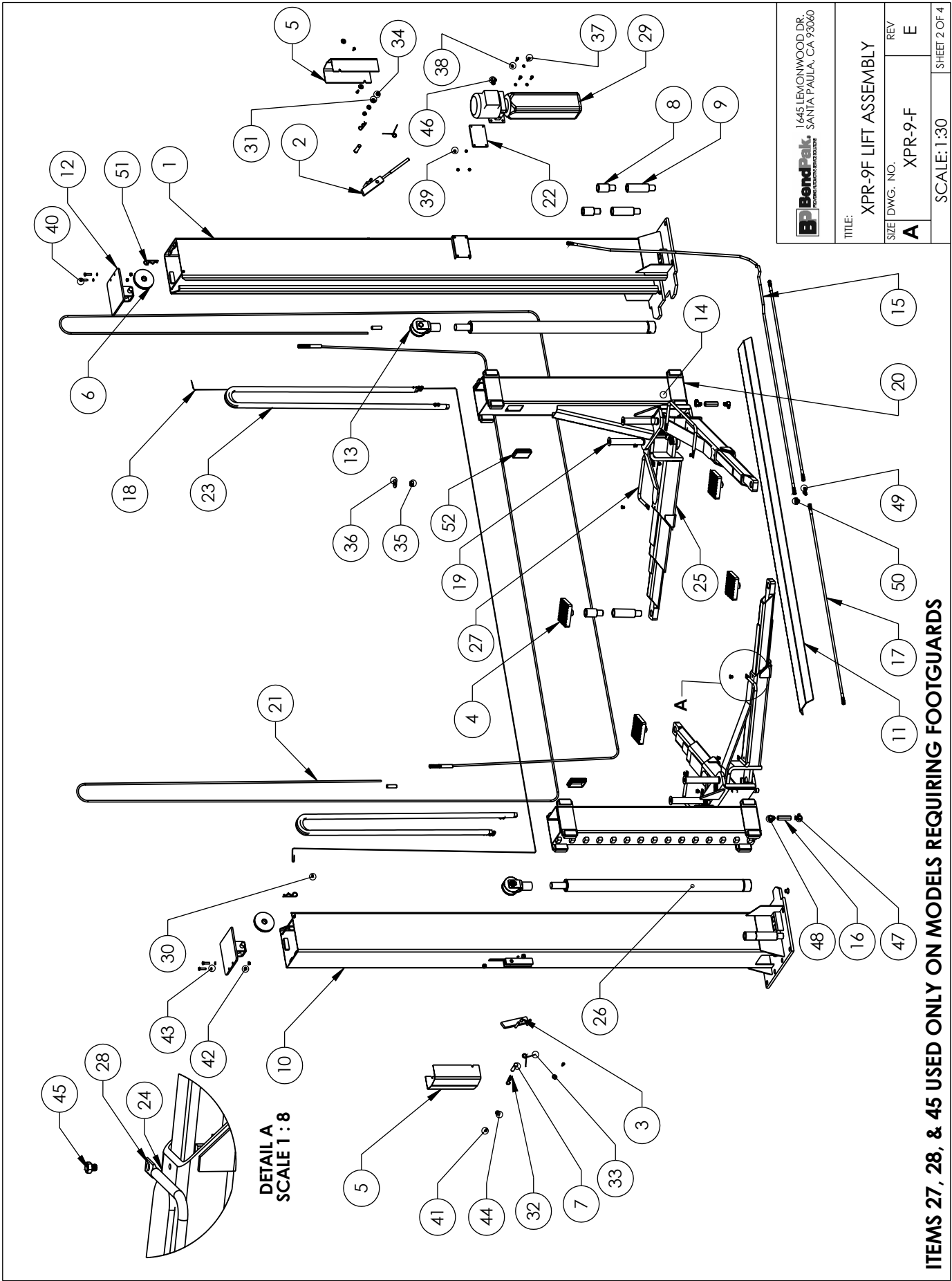

BendPak 1645 LEMONWOOD DR.
 FORTY-EIGHT YEARS OF INNOVATION
 SANTA PAULA, CA 93060

TITLE:	XPR-9F LIFT ASSEMBLY		
SIZE/DWG. NO.:	A XPR-9-F		
REV:	E		
SCALE:	1:30		
	SHEET 2 OF 4		

ITEMS 27, 28, & 45 USED ONLY ON MODELS REQUIRING FOOTGUARDS

DETAIL A
SCALE 1:8

BendPak 1445 LEMONWOOD DR.
SANTA PAULA, CA 93060

TITLE:	XPR-9F LIFT ASSEMBLY		
SIZE:	DWG. NO.	REV	
A	XPR-9-F	E	
SCALE: 1:40			SHEET 3 OF 4

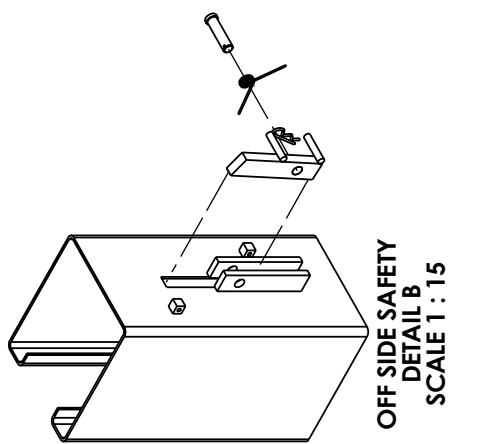
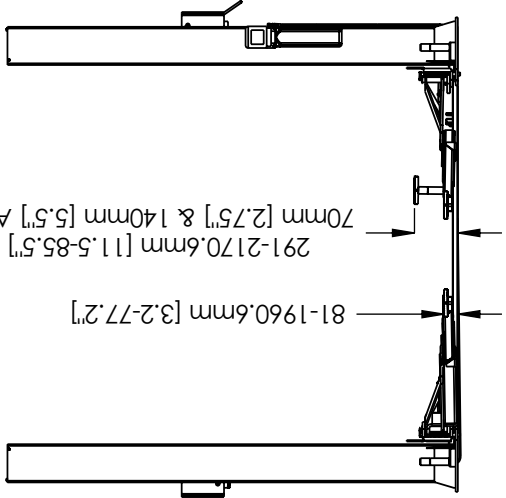
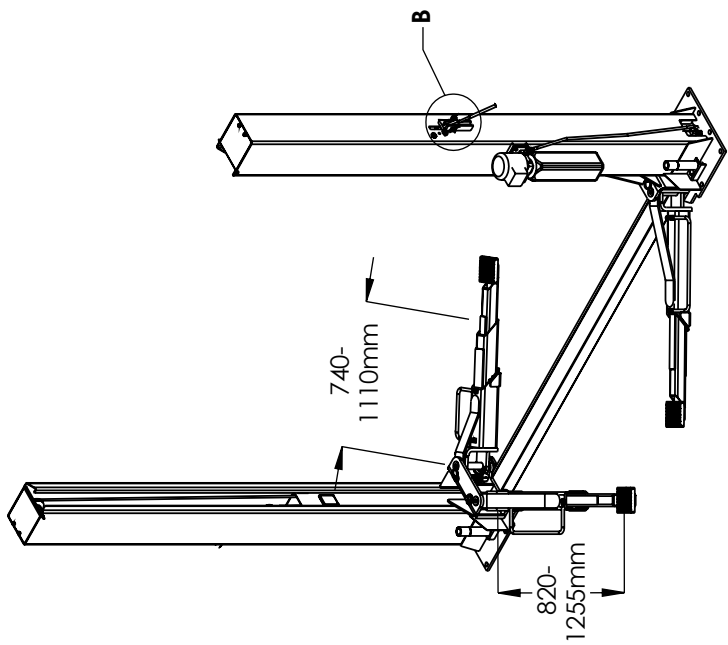
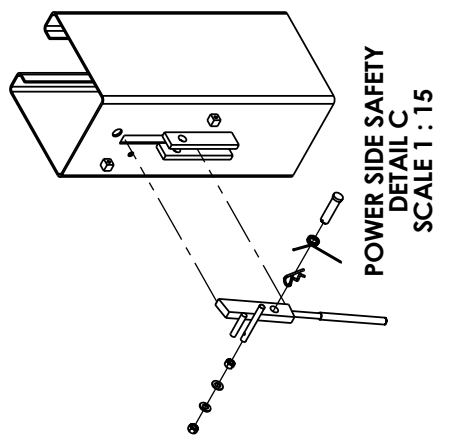
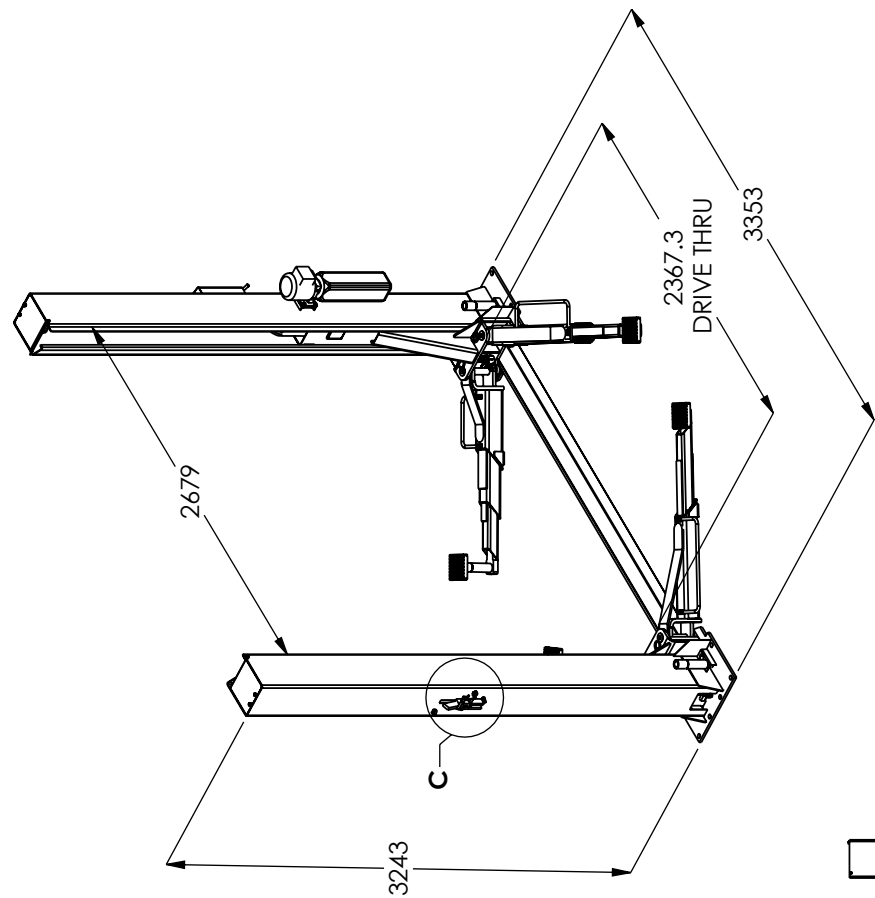

ITEM NO.	PART NUMBER	DESCRIPTION	QTY.	REV
1	800374	XP/XPR-9-FX GROUND PLATE	1	PRE-003
2	801073	XPR-9F/FX POWER SIDE POST ASSEMBLY	1	E-001
3	FG-800295	XP-9F/FX OFF SIDE POST ASSEMBLY	1	PRE-005
4	800309	XP/XPR-9F/FX CHAIN ROLLER ASSEMBLY	2	B
5	800868	XPR-9F/FX LIFT HEAD ASSEMBLY	2	D-002
6	800300	TOP EQUALIZER	2	PRE-004
7	700583	PULLEY PLATE WELDMENT	2	PRE-005
8	800124	CYLINDER ASSEMBLY Ø 2.5 x 3.7	2	PRE-004
9	AB-1551	XP-9F/FX TO SHAFV ASSEMBLY	6	PRE-008
10	800112	POWER UNIT	2	PRE-003
11	800191	OFF SIDE COVER	2	B
12	800100	SAFETY CLEVIS PIN	2	PRE-004
13	800104	POWER SIDE SAFETY WELDMENT	1	PRE-004
		OFF SIDE SAFETY WELDMENT	1	PRE-004
		MALE BULKHEAD TEE	1	
14	.44x.38 TEE-FIT	7/16-18 UNF 2A	1	--
		37° FLARE TO		
		9/16-20 UNF		
		90° ELBOW		
15	90° .56 MALE-.38 FEM NPT	MALE 9/16-18 UNF	1	--
		37° FLARE TO		
		FEMALE 3/8-18 NPT 2B		
		1" LONG		
16	90.375ElbowORing	90° ELBOW 37° MALE FLARE 9/16-18 UNF-2A	1	--
		TO 3/8-18 NPT-2A, ADJUSTABLE O-RING		
17	90deg.375NPT-.44	90° ELBOW 3/8-18 NPT	2	--
		TO 7/16-20 UNF MALE THREAD		
18	90deg.375NPT	90° ELBOW 3/8-18 NPT	2	--
		TO 3/8-18 NPT MALE THREAD		
19	800330	3/8-18 NPT TUBE FITTING	2	--
20	OVAl STEVE	SAFETY CABLE CRIMP	1	PRE-002
21	WASHER	Ø 25 x 13 x 1.5mm FLAT WASHER	2	--
22	WASHER	Ø 50 x 20 x 3.0mm W WASHER	2	--
23	WASHER	10 I.D. x 28 O.D. x 1.5	4	--
24	16 DIA. HAIRPIN COTTER	Ø 3.75 x 68mm	2	--
25	800200	2.5 WIRE DIA. Ø 25.5 x 150 LG.	2	PRE-004
26	HN M12x1.75	HEX NUT M12 x 1.75	2	--
27	HN M18 x 2.5	HEX NUT M18 x 2.5	2	--
28	HHB M8 x 1.25 x 18	HEX HEAD BOLT	8	--
29	8 x 15 x 2 LW	SPRING LOCK WASHER	4	--
30	10 x 18 x 2.3 LW	SPRING LOCK WASHER	4	--
31	HN M8 x 1.25	HEX NUT M8 x 1.25	4	--
32	HHB M10 x 1.5 x 38	HEX HEAD BOLT M10 x 1.5 x 38	4	--
33	HN M10 X 1.5	HEX NUT	4	--
34	22 DIA. HAIRPIN COTTER	Ø 4.5 x 75mm	6	--
35	LP-800979	LOW PROFILE MEDIUM ARM ASSEMBLY	2	D
36	LP-800992	XPR-9F/10 LOW PROFILE TRIPLE TELESCOPING ARM	2	F
37	800750	LIFT HEAD PIN WELDMENT	4	B
38	800106	SLIP ON LIFT PAD ASSEMBLY	4	PRE-005
39	800207	SHORT LIFT PAD EXTENSION (113mm LG.)	4	B
40	800208	LONG LIFT PAD	4	PRE-008
		EXTENSION (182mm LG.)		
41	FG-801017	ARM FOOT GUARD (526mm)	2	D
42	FG-801018	XPR-9F/FDX/10C/X/ACX TRIPLE TELESCOPING ARM ASSEMBLY	2	D
		FOOT GUARD (330mm)		
43	HHB M10 x 1.5 x 10	HEX HEAD BOLT	8	--
44	800392	Ø 6.35 x 3150mm LG. POWER UNIT HYDRAULIC HOSE ASSEMBLY	1	PRE-003
		(124")		
45	800378	Ø 2.4mm x 7544LG. SAFETY CABLE	1	PRE-004
46	800375	Ø 6.35 x 1524LG. HYDRAULIC HOSE	2	PRE-004
47	800332	XP/XPR-9F/FX CYLINDER CHAIN	2	A
48	801076	XPR-9F/FX Ø 10 x 9386LG. EQUALIZER CABLE ASSEMBLY	1	A-001
49	801105	POWER UNIT VIBRATION DAMPENER	2	PRE-002
50	800326	HYDRAULIC PLUG	2	B-004
51	P-543	XPR PLASTIC COVER BLOCK 105x80	2	A

DO NOT SCALE DRAWING

DIMENSIONS ARE IN MM

TOLERANCES: MACH: ± 1/2°

ANGULAR: MACH: ± 1/2°

SURFACE FINISH: MACHINED SURFACES: LA FINISH UNLESS OTHERWISE SPECIFIED.

MATERIAL: ---

SIZE: ---

TEXT ASSEMBLY: ---

NAME: TM

DATE: 06/21/2007

CHECKED: AC

11/16/2007

THIRD ANGLE PROJECTION

1645 LEMONWOOD DR. BENDPAK. SANTA PAULA, CA 93060

TITLE: XPR-9FX LIFT ASSEMBLY

SCALE: 1:35

REV: E

SHEET 1 OF 4

BendPak 1645 LEMONWOOD DR.
SANTA PAULA, CA 93060

TITLE: XPR-9FX LIFT ASSEMBLY

SIZE DWG. NO. XPR-9-FX

REV E

SCALE: 1:30

SHEET 2 OF 4

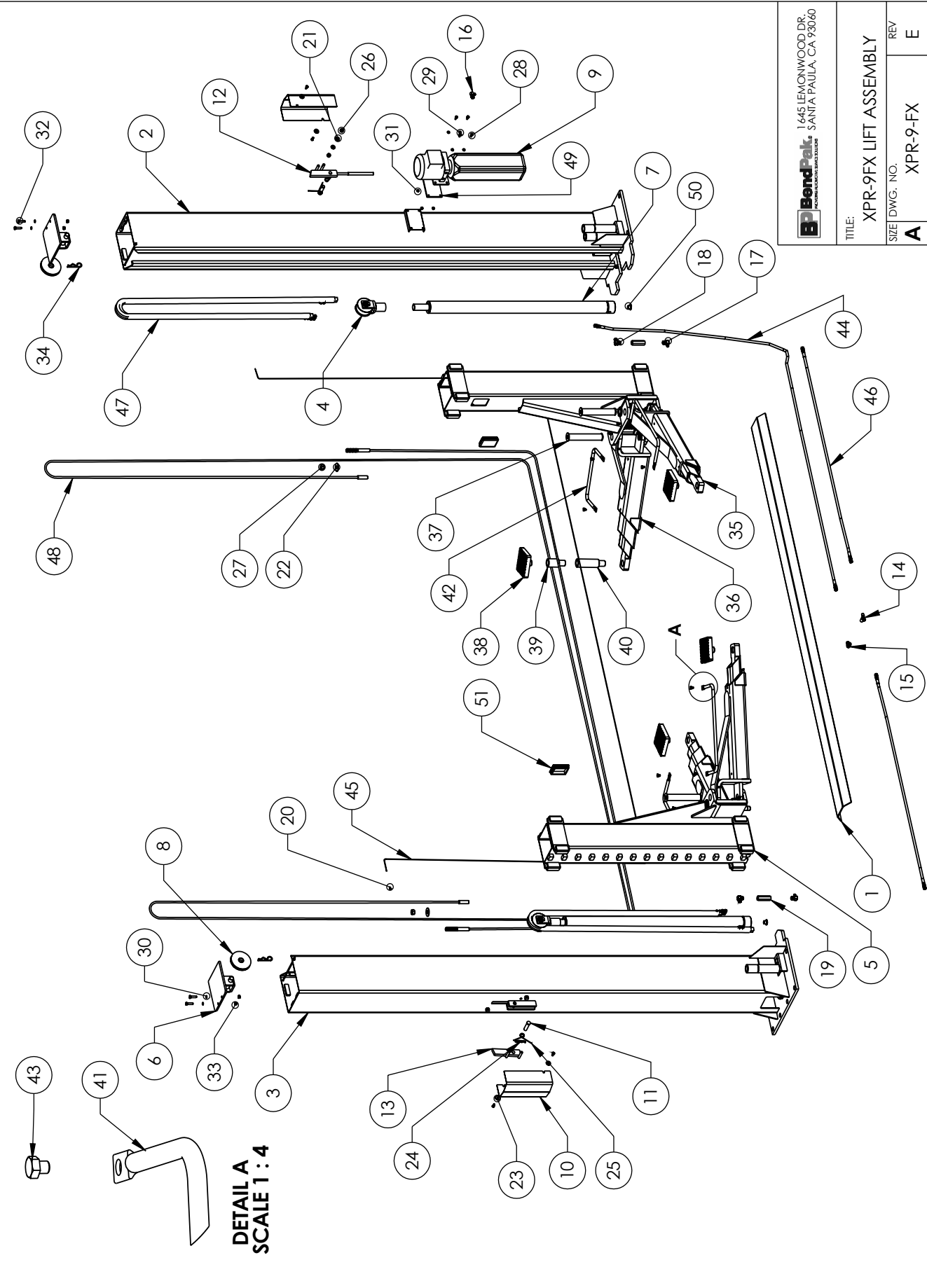

ITEMS 41, 42, & 43 USED ONLY ON MODELS REQUIRING FOOTGUARDS

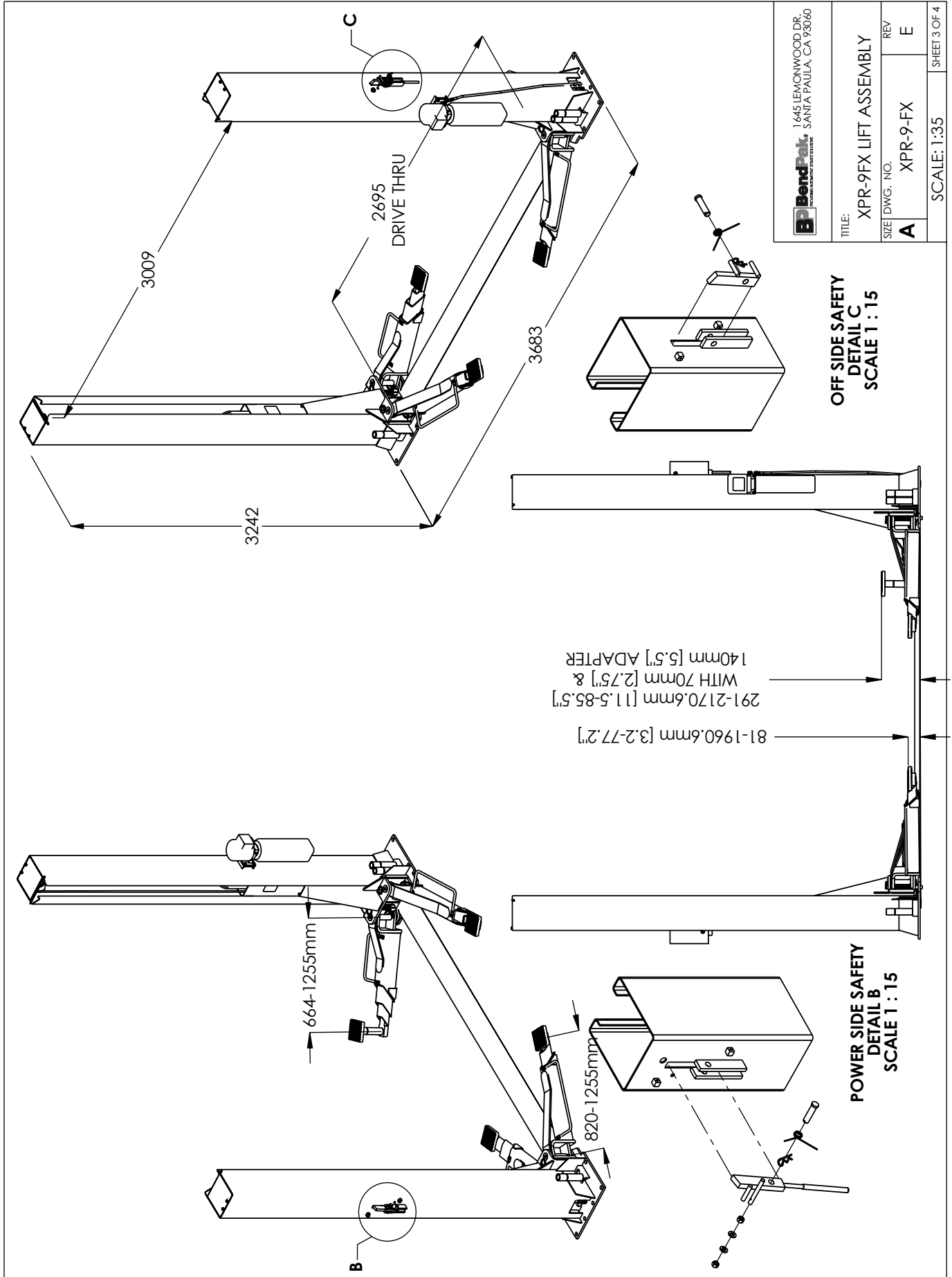

 1645 LEMONWOOD DR. SANTA PAULA, CA 93060	
TITLE:	XPR-9FX LIFT ASSEMBLY
SIZE DWG. NO.	A
REV	E
SCALE: 1:35	
SHEET 3 OF 4	

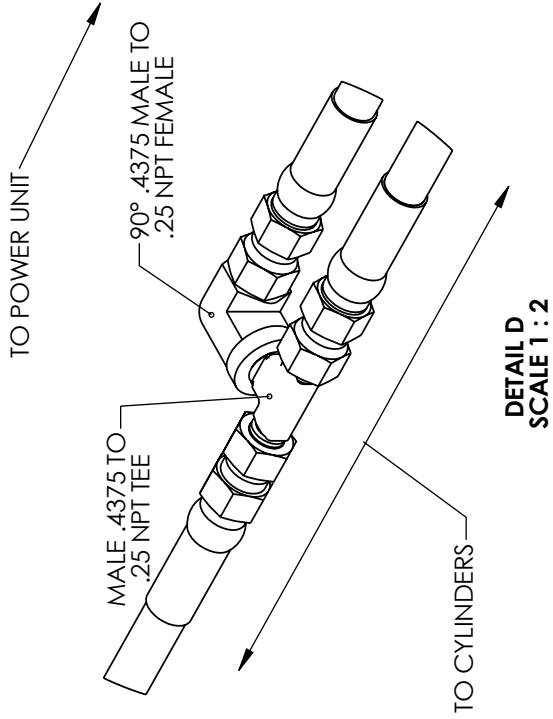
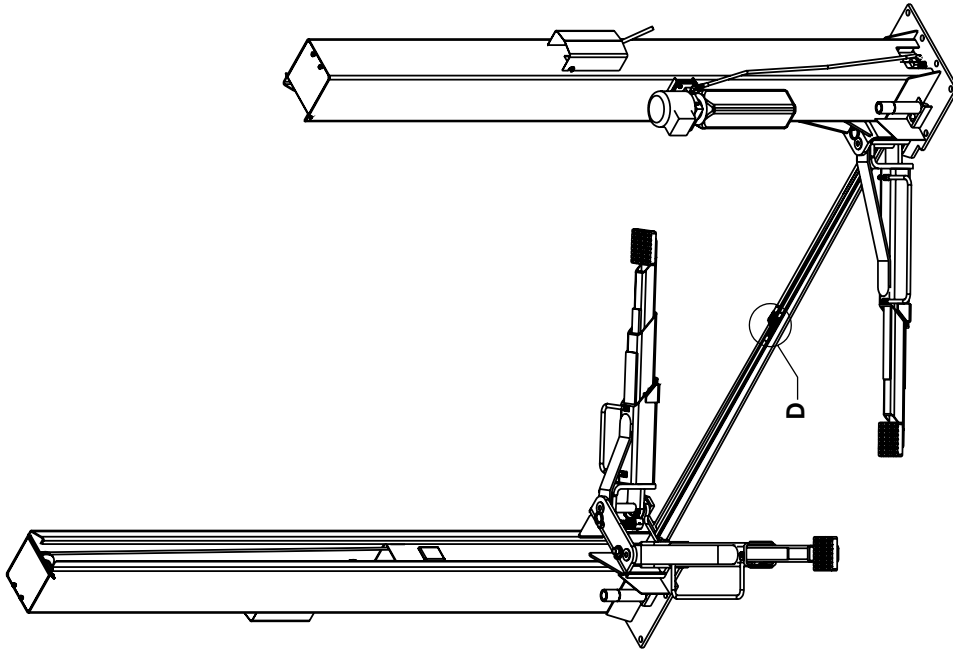

BendPak 1645 LEMONWOOD DR.
SANTA PAULA, CA 93060

TITLE: XPR-9F LIFT ASSEMBLY	
SIZE DWG. NO. A XPR-9-F	REV E
SCALE: 1:30	SHEET 4 OF 4

INSTALLATION FORM

Customer Name:		Date of Installation:
Company Name:		
Street Address:		
City:	State:	Zip:
Phone:	Fax:	

Pre-Install Agreement

I, (the undersigned) acting as the owner of the business listed above assume responsibility for any permits required, either state or county mandated, related to the installation and/or operation of this equipment. I assume responsibility for the concrete floor and condition thereof, now or later, where the above equipment model(s) are installed. I will assume all liability for losses, damages (including loss of use), expenses, demands, claims, and judgments in connection with or arising out of any personal injury or alleged damage to property, sustained or alleged to have been sustained in connection with, or to have arisen out of the condition and/or drilling of the concrete near or adjacent to the equipment model(s) listed above. If my employee(s) offer assistance of any kind during installation of the above equipment model(s) I hold the manufacturer and installation company harmless of all liability for losses, damages, expenses, claims, and judgments in connection with or arising out of any personal injury or alleged damage to property, sustained or alleged to have been sustained in connection with the installation of the above equipment model(s).

I understand that the lifts above are supplied with concrete fasteners meeting the criteria of the American National Standard "Automotive Lifts - Safety Requirements for Construction, Testing, and Validation" ANSI/ALI ALCTV-1998, and that I will be responsible for all charges related to any special regional structural and/or seismic anchoring requirements specified by any other agencies and/or codes such as the Uniform Building Code (UBC) and/or International Building Code (IBC).

Customer Signature: _____ Print Name: _____ Date: _____

Post-Installation Check-Off

- | | |
|--|--|
| <input type="checkbox"/> Base and Columns Properly Shimmed And Stable
<input type="checkbox"/> Anchor Bolts Tightened
<input type="checkbox"/> Runways Properly Attached and Secured
<input type="checkbox"/> Electric Power Supply Confirmed
<input type="checkbox"/> Cables / Chains Adjusted Properly
<input type="checkbox"/> Safety Locks Functioning Properly
<input type="checkbox"/> Check For Hydraulic Leaks
<input type="checkbox"/> Oil Level | <input type="checkbox"/> Lubrication of Critical Components
<input type="checkbox"/> Lift Adapters
<input type="checkbox"/> Check For Overhead Obstructions
<input type="checkbox"/> Runways Level
<input type="checkbox"/> All Screws, Bolts, and Pins Secured
<input type="checkbox"/> Surrounding Area and Lift Clean In Appearance
<input type="checkbox"/> Proper Operation, Maintenance and Safety Explained
<input type="checkbox"/> Operation and Safety Manual(s) Left at Site |
|--|--|

I, (the undersigned) confirm that the above installation procedure(s) were completed. I understand that I will be responsible for maintaining this equipment as outlined in the accompanied **Installation and Operation Manual** and **ANSI/ALI ALOIM Safety Requirements for Operation, Inspection and Maintenance**. I understand that personal injury and/or damage to property can occur if the above equipment model(s) are not maintained or used improperly and take full responsibility for training my employees on proper use and maintenance of this equipment. I hold the manufacturer and installation company harmless of all liability for losses, damages (including loss of use), expenses, demands, claims, and judgments in connection with or related to improper use, improper training, or lack of required maintenance. I understand that the warranty does not cover replacement of parts worn or damaged due to normal use or lack of required maintenance

Customer Signature: _____ Print Name: _____ Date: _____

Installer Signature: _____ Print Name: _____ Date: _____

Installer Company Name: _____

Street Address: _____

City: _____ State: _____ Zip: _____

Phone: _____ Phone (Other): _____



The best automotive service equipment on the planet.

**For Parts Or Service
Contact:**

**BendPak Inc. / Ranger Products
1645 Lemonwood Dr.
Santa Paula, CA. 93060**

**Tel: 1-805-933-9970
Toll Free: 1-800-253-2363
Fax: 1-805-933-9160**

**www.bendpak.com
www.rangerproducts.com**

